



Hughes Low Profile BGAN (LPB) Terminal

User Guide

H71551
Revision E
April 4, 2024



Copyright © 2014 – 2015, 2017, 2019, 2024 Hughes Network Systems, LLC

All rights reserved. This publication and its contents are proprietary to Hughes Network Systems, LLC. No part of this publication may be reproduced in any form or by any means without the written permission of Hughes Network Systems, LLC, 11717 Exploration Lane, Germantown, Maryland 20876.

Hughes Network Systems, LLC has made every effort to ensure the correctness and completeness of the material in this document. Hughes Network Systems, LLC shall not be liable for errors contained herein. The information in this document is subject to change without notice. Hughes Network Systems, LLC makes no warranty of any kind with regard to this material, including, but not limited to, the implied warranties of merchantability and fitness for a particular purpose.

Trademarks

Hughes and Hughes Network Systems are trademarks of Hughes Network Systems, LLC. All other trademarks are the property of their respective owners.

Contents

Understanding safety alert messages	vii
Messages concerning personal injury / Messages concernant des blessures corporelles.....	vii
Messages concerning property damage / Messages concernant des dommages matériels	viii
Safety symbols	ix
Chapter 1 Product Description	1
Contents of the Hughes LPB Terminal	1
Main features of the LPB Terminal	2
Interfaces.....	4
Terminal Specifications	6
Information for Maintenance	7
Date of Manufacture	7
Manufacturer Contact	7
Chapter 2 Configuration via Web UI.....	8
Web UI Layout	8
Home Tab.....	8
Terminal Information.....	8
SIM Information	8
Troubleshooting	9
Status Bar	10
Connections Tab	12
Manage Contexts Page.....	12
Automatic Contexts.....	13
Manage APNs Page.....	15
Settings Tab	16
General Setup.....	16
IP Address/DHCP Settings	17
Ethernet Port Page.....	18
Port Forwarding Page.....	20
ATC Page.....	21
Feature Management Page	22
M2M Page.....	23
Ping Configuration:.....	23
Security Passwords	25
Enhanced Security Settings Page.....	26
SMS Pages	28

Chapter 3	Operational Features	29
LEDs		29
Function Button		29
Network Mode		29
NAT Mode		30
NAPT Mode		30
Relay Mode		30
PPPoE Mode		31
Remote Control		31
Remote Upgrade and File Transfer		32
Security		32
Wake on LAN (Any Packet)		33
Power Pin Control		34
ATC		34
Watchdog		34
Chapter 4	Installation Instructions	35
Inspecting the parts		35
Determining where to install the terminal		35
Install Ethernet, Power and RF Cables		37
Powering up the Hughes LPB		39
Coverage Map		40
Pointing the Antenna		41
Post Antenna Pointing		43
LED Flow Chart		45
Exit Pointing Mode		46
Chapter 5	Lightning Protection and Safety	47
Lightning and Grounding Precautions / La foudre et la terre Précautions		47
Disclaimer / Avertissement		49
Chapter 6	AT Unsolicited Response Codes	50
Chapter 7	Troubleshooting	52
PDP Context Activation Errors		53
Chapter 8	Regulatory Notices	54
FCC Compliance / Conformité FCC		54
IC Compliance / Conformité IC		54
EU WEEE (Waste Electrical and Electronic Equipment) Directives		55
MIL-STD-810G (15 April-14)		55

Figures

FIGURE 1-1 – HUGHES LPB TERMINAL	1
FIGURE 1-2 – ACCESSORIES BOX	2
FIGURE 1-3 - INTERFACES	4
FIGURE 1-4 – DOOR OPEN VIEW	5
FIGURE 2-1 - HOME PAGE	9
FIGURE 2-2 – MANAGE CONTEXTS	12
FIGURE 2-3 – AUTOMATIC CONTEXTS	13
FIGURE 2-4 – DHCP AUTOMATIC CONTEXTS	14
FIGURE 2-5 – MANAGE APNS	15
FIGURE 2-6 – GENERAL SETUP	16
FIGURE 2-7 – IP ADDRESS/DHCP SETTINGS	18
FIGURE 2-8 – ETHERNET SETTINGS	19
FIGURE 2-9 – PORT FORWARDING SETTINGS	20
FIGURE 2-10 – ATC PAGE	21
FIGURE 2-11 – FEATURE MANAGEMENT PAGE	22
FIGURE 2-12 – M2M SETUP	23
FIGURE 2-13 – SECURITY PASSWORDS	25
FIGURE 2-14 – ENHANCED SECURITY PAGE LINK	26
FIGURE 2-15 – ENHANCED SECURITY SETTINGS PAGE	26
FIGURE 2-16 – LOGIN PAGE	27
FIGURE 2-17 – SMS SEND/RECEIVE	28
FIGURE 4-1 – HOME PAGE SHOWING POINTING INFORMATION	36
FIGURE 4-2 INSTALLING ETHERNET, POWER AND RF CABLE	37
FIGURE 4-3 CABLES CONNECTED: RF, 3-PIN AND 6-PIN RESPECTIVELY	38
FIGURE 4-4 - FUNCTION BUTTON	39
FIGURE 4-5 INMARSAT SATELLITE COVERAGE	40
FIGURE 4-6: TYPICAL LAY FLAT ANTENNA POINTING 30° - 60° ELEVATION ANGLE	42
FIGURE 4-7: 0° TO 30° ELEVATION ANGLE	42
FIGURE 4-8: 60°- 90° ELEVATION ANGLE	43
FIGURE 4-9 – SIGNAL STRENGTH ON HOME PAGE	44
FIGURE 4-10 – LED FLOW CHART	45
FIGURE 5-1 – LPB PROTECTIVE EARTH GROUNDING	48



Tables

TABLE 1 – TERMINAL SPECIFICATIONS	6
TABLE 2 – WEB UI LAYOUT	8
TABLE 3 – STATUS BAR	10
TABLE 4 – GPS STATUS	11
TABLE 5 – REMOTE CONTROL SMS MESSAGE COMMANDS	32
TABLE 6 - AT UNSOLICITED RESPONSE CODES.....	51
TABLE 7 - PDP CONTEXT ACTIVATION ERRORS	53

Understanding safety alert messages

Safety alert messages call attention to potential safety hazards and tell you how to avoid them. These messages are identified by the signal words DANGER, WARNING, CAUTION, or NOTICE, as illustrated below. To avoid possible property damage, personal injury or in some cases possible death read and comply with all safety alert messages.

Messages d'alerte de sécurité attirent l'attention sur les dangers potentiels et de vous dire comment les éviter. Ces messages sont identifiés par un signal mots DANGER, AVERTISSEMENT, ATTENTION, ou avis, comme illustré ci-dessous. Pour éviter des dommages matériels, des blessures ou la mort dans certains cas possible de lire et de respecter tous les messages d'alerte de sécurité.

Messages concerning personal injury / Messages concernant des blessures corporelles

The signal words DANGER, WARNING, and CAUTION indicate hazards that could result in personal injury or in some cases death, as explained below. Each of these signal words indicates the severity of the potential hazard.

Le signal de DANGER mots, AVERTISSEMENT et ATTENTION indiquer les dangers qui pourraient entraîner des blessures ou, dans certains cas la mort, comme expliqué ci-dessous. Chacun de ces mots du signal indique la gravité du danger potentiel.



DANGER indicates a potentially hazardous situation which, if not avoided, will result in death or serious injury.

DANGER indique une situation potentiellement dangereuse qui, si elle n'est pas évitée, entraînera la mort ou des blessures graves.

 **WARNING**

WARNING indicates a potentially hazardous situation which, if not avoided, could result in serious injury.

AVERTISSEMENT indique une situation potentiellement dangereuse qui, si elle n'est pas évitée, pourrait entraîner des blessures graves.

 **CAUTION**

CAUTION indicates a potentially hazardous situation which, if not avoided, could result in minor or moderate injury.

ATTENTION indique une situation potentiellement dangereuse qui, si elle n'est pas évitée, pourrait entraîner des blessures mineures ou modérées.

**Messages concerning
property damage /
Messages concernant des
dommages matériels**

NOTICE

NOTICE is used for messages concerning possible property damage, product damage or malfunction, data loss, or other unwanted results—but *not* personal injury.

AVIS est utilisée pour les messages concernant les dommages matériels, des dommages au produit ou de dysfonctionnement, de perte de données ou d'autres résultats indésirables, mais des blessures non personnelle.

Safety symbols

The generic safety alert symbol  calls attention to a potential personal injury hazard. It appears next to the DANGER, WARNING, and CAUTION signal words as part of the signal word label. Other symbols may appear next to DANGER, WARNING, or CAUTION to indicate a specific type of hazard (for example, fire or electric shock). If other hazard symbols are used in this document they are identified in this section.

Le symbole générique d'alerte suivant  attire l'attention sur un danger potentiel de risque de blessures. Il apparaît à côté des mots DANGER, AVERTISSEMENT et ATTENTION dans le cadre de l'affichage d'alerte. D'autres symboles peuvent apparaître à côté de DANGER, AVERTISSEMENT ou ATTENTION pour indiquer un type spécifique de danger (par exemple, un incendie ou un choc électrique). Si d'autres symboles de danger sont utilisés dans ce document, ils sont décrits dans cette section.

Additional symbols / Symboles supplémentaires



Warning Potential Radio Frequency (RF) hazard. Where you see this alert symbol and WARNING heading, strictly follow the warning instructions to avoid injury to eyes or other personal injury.

Avertissement Danger possible de Fréquence Radio (RF). A la vue de ce symbole d'alerte et du terme AVERTISSEMENT, suivez rigoureusement les instructions d'avertissement afin d'éviter une blessure aux yeux ou toute autre blessure.



Warning Where you see this alert symbol and WARNING heading, strictly follow the warning instructions to avoid personal injury.

Avertissement A la vue de ce symbole d'alerte et du terme AVERTISSEMENT, suivez rigoureusement les instructions d'avertissement pour éviter toute blessure.



Danger Electric shock hazard: Where you see this alert symbol and DANGER heading, strictly follow the warning instructions to avoid electric shock injury or death.

Danger **Risque de choc électrique:** A la vue de ce symbole d'alerte et du terme **DANGER**, suivez rigoureusement les instructions d'avertissement pour éviter tout choc électrique ou blessure mortelle.

Warnings for Satellite Terminal / Avertissements pour le Terminal Satellite



Do not stand in front of the Antenna This device emits radio frequency energy. To avoid injury, do not place head or other body parts in front of the satellite antenna when system is operational. Maintain a distance of 1 m or more from the front of the Satellite Terminal antenna.

Ne pas se tenir en face de l'antenne. Cet appareil émet une énergie de fréquence radio. Pour éviter toute blessure, ne placez pas la tête ou toute autre partie du corps en face de l'antenne satellite lorsque le système est opérationnel. Maintenez une distance de 1 m ou plus par rapport à l'antenne du terminal satellite.



General Handle your Satellite Terminal with care. Avoid exposing your Satellite Terminal to extreme hot or cold temperatures outside the range -40°C to +75°C.

Avoid placing the Terminal close to cigarettes, open flames or any source of heat.

Changes or modifications to the Terminal not expressly approved by Hughes Network Systems will void the Warranty and could void your authority to operate this equipment.

Only use a soft damp cloth to clean the Terminal.

To avoid impaired Terminal performance, please ensure the unit's antenna is not damaged or covered with foreign material like paint or labeling.

When inserting the SIM, do not bend it or damage the contacts in any way. When connecting the interface cables, do not use excessive force.

Général Manipulez votre terminal satellite avec soin. Évitez d'exposer votre terminal satellite à des températures extrêmement chaudes ou froides en dehors de la plage -40 ° C à 75 ° C.

Évitez de placer le terminal à proximité de la cigarette, de flammes nues ou de toute source de chaleur.

Les changements ou modifications apportées au Terminal et non expressément approuvées par Hughes Network Systems annulent la garantie et peuvent annuler votre droit à utiliser cet équipement.

Utilisez uniquement un chiffon doux humide pour nettoyer le terminal.

Pour éviter toute dégradation des performances du terminal, veuillez vous assurer que l'antenne de l'unité n'est pas endommagée ou recouverte d'un corps étranger, comme de la peinture ou de l'étiquetage.

Lorsque vous insérez la carte SIM, ne pas la plier ni endommager les contacts en aucune manière. Ne pas forcer lors de la connexion des câbles d'interface.



In the vicinity of blasting work and in explosive environments Never use the Satellite Terminal where blasting work is in progress. Observe all restrictions and follow any regulations or rules. Areas with a potentially explosive environment are often, but not always, clearly marked.

A proximité de travaux de dynamitage et d'environnements explosifs N'utilisez jamais le terminal satellite près de travaux de dynamitage en cours. Respectez toutes les restrictions et suivez toutes les instructions ou la réglementation. Les zones présentant une atmosphère potentiellement explosive sont généralement, mais pas toujours, clairement signalées.



Qualified Service Do not attempt to disassemble your Satellite Terminal. The unit does not contain consumer-serviceable components. Only qualified service personnel may install or repair equipment.

Service Qualifié N'essayez pas de démonter votre terminal satellite. L'unité ne contient pas de composants réparables par le consommateur. Seul le personnel qualifié peut installer ou réparer le matériel.



Accessories Use Hughes approved accessories only. Use of non-approved accessories may result in loss of performance, damage to the Satellite Terminal, fire, electric shock or injury.

Accessoires Utilisez uniquement des accessoires approuvés par Hughes. L'utilisation d'accessoires non approuvés peut entraîner une dégradation de performance, un endommagement du terminal satellite, un incendie, une électrocution ou des blessures.



Connecting Devices Never connect incompatible devices to the Satellite Terminal. When connecting the Satellite Terminal to any other device, read the device's User Manual for detailed safety instructions.

Connexion de périphériques Ne jamais connecter des périphériques incompatibles au terminal satellite. Lors du raccordement du terminal satellite à un autre appareil, lisez le manuel utilisateur du périphérique pour les instructions détaillées de sécurité.



Pacemakers The various brands and models of cardiac pacemakers available exhibit a wide range of immunity levels to radio signals. Therefore, people who wear a cardiac pacemaker and who want to use a Satellite Terminal should seek the advice of their cardiologist. If, as a pacemaker user, you are still concerned about interaction with the Satellite Terminal, we suggest you follow these guidelines:

- Maintain a distance of one meter from the front and sides of the antenna and your pacemaker;
- Refer to your pacemaker product literature for information on your particular device.

If you have any reason to suspect that interference is taking place, turn off your Satellite Terminal immediately.

Stimulateurs Cardiaques Les différentes marques et modèles de stimulateurs cardiaques disponibles présentent un large éventail de niveaux d'immunité aux signaux radio. Par conséquent, les personnes qui portent un stimulateur cardiaque et qui veulent utiliser un terminal satellite doivent demander l'avis de leur cardiologue. Si, en tant qu'utilisateur de stimulateur cardiaque, vous êtes toujours soucieux d'une éventuelle interaction avec le terminal satellite, nous vous suggérons de suivre ces directives:

- Maintenez un mètre de distance entre votre stimulateur cardiaque et l'avant ou les côtés de l'antenne;
- Reportez-vous à la documentation de votre stimulateur cardiaque pour toute information spécifique à celui-ci.

Si vous avez un doute que des interférences se produisent, éteignez votre terminal satellite immédiatement.



Hearing Aids Most new models of hearing aids are immune to radio frequency interference from Satellite Terminals that are more than 2 meters away. Many types of older hearing aids may be susceptible to interference, making it very difficult to use them near a Terminal. Should interference be experienced, maintain additional separation between you and the Satellite Terminal.

Appareils Auditifs La plupart des nouveaux appareils auditifs sont insensibles aux interférences dues aux fréquences radio des terminaux satellites situés à plus de 2 m. De nombreux modèles plus anciens peuvent être sensibles aux interférences, ce qui les rend très difficiles à utiliser à proximité d'un terminal. En cas d'interférences détectées, veuillez maintenir une distance supplémentaire entre vous et le terminal.



Electrical Storms installation of the Satellite Terminal during electrical storms may result in severe personal injury or death.

Orages Electriques L'installation d'un terminal satellite pendant un orage électrique peut entraîner des blessures graves ou mortelles.



Protective Earth Grounding is recommended by Hughes for the satellite terminal. Please consult professional local advice for these requirements.

Une mise à la terre de protection est recommandée par Hughes pour le terminal satellite. Veuillez consulter un conseil professionnel local pour ces spécifications.

Chapter 1 Product Description

Contents of the Hughes LPB Terminal

The Hughes Low Profile BGAN (LPB) Kit (P/N 3500910-0001) is a two-piece design that has an IP-67 enclosure and a lay-flat directional antenna that can be used in the harshest environments and in unmanned/remote locations. The kit includes the following items:

- Main box:
 - Modem
 - Lay flat antenna
- Accessories box:
 - 2 RF cables
 - Pointing wedge
 - Interface cables
 - Ethernet - 6-pin Amphenol connector to RJ-45
 - Power – 3-pin Amphenol connector to banana jacks

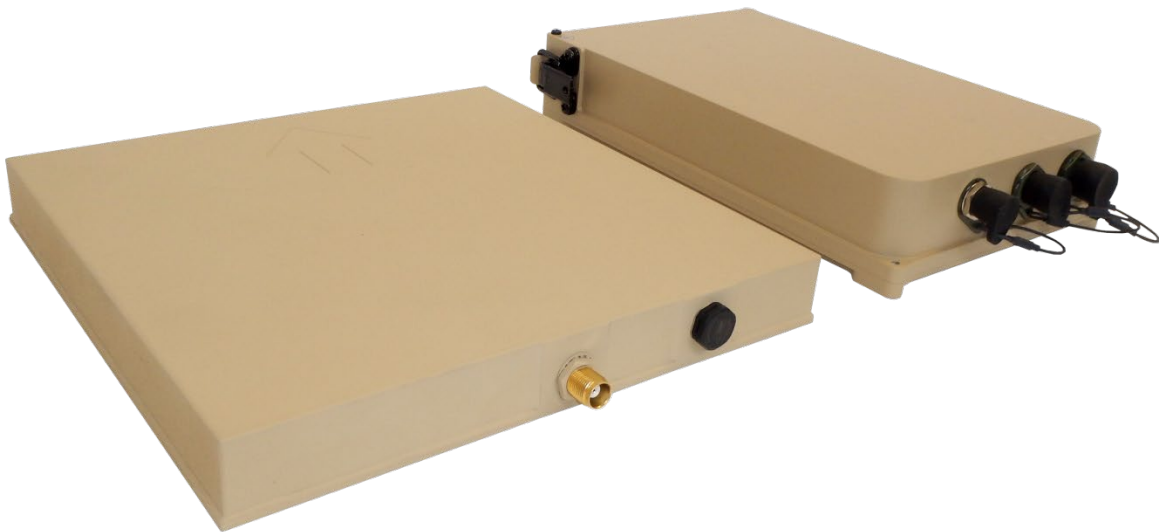

Figure 1-1 – Hughes LPB Terminal



Figure 1-2 – Accessories box

Main features of the LPB Terminal

The main features of the Hughes LPB terminal are listed below:

- Use of Internet Protocol (IP) via the BGAN satellite network
- Remote Management
 - Web UI interface
 - SMS Control
 - AT Command Control
 - Log file upload
 - Terminal configuration
 - Remote firmware upgrade
- Power Savings and Sleep Mode
- IP Watchdog
- XL-band ready
- NAT, NAPT, Relay and PPPoE Modes

- Auto Power ON when power is applied
- Automatic PDP Context Activation (Static or DHCP)
- Dedicated M2M Web UI
- Security
 - Ethernet MAC Filtering
 - Administration Password
 - SMS Control password
 - White List for SMS control
 - AT Command password lock
 - SIM Personalization
 - Phone-to-SIM
 - DP SIM Lock
 - SP SIM Lock

Interfaces

The Hughes LPB has the following interfaces (Figure 1-3 from left to right):

- TNC RF connector for lay flat directional L-band antenna
- 3-pin Amphenol connector that provides power control to the terminal
- 6-pin Amphenol connector that provides Ethernet connectivity to terminal

With front door open (see Figure 1-4), the following items are accessible:

- USIM card slot
- 3 LEDs for Power, GPS and Network connectivity
- 3.5 mm stereo audio jack for audio tone or voltage level to assist in antenna pointing
- A single function button
- USB 1.1 connection (USB Type-B) for PC to configure terminal (requires installation of Hughes USB driver. See bgan.hughes.com)



Figure 1-3 - Interfaces



Figure 1-4 – Door Open View

Terminal Specifications

Technical Specifications	
Satellite TX Frequency	@ 1626.5 – 1660.5MHz
Satellite RX Frequency	@ 1525 – 1559 MHz
Modem Weight:	2.2 Kg
Modem Dimensions:	254 mm x 177 mm x 53 mm
Antenna Weight:	1.5kg
Antenna Dimensions:	240 mm x 240 mm x 29 mm
Operating Temperature	-40°C to +75°C
Storage Temperature	-45°C to +80°C
Humidity	95% RH at +40°C
Antenna and modem - Water and Dust	IP-67 Compliant
Non-operational Mechanical Vibration	200-2000Hz,0.3 m2/s3; MIL-SPEC 810B Method 500.3 proc. 1
Input Power	2A @ 12V +/-10% or 1A @ 24V +/-10%
IP-67 rated 3-pin Connector	Pins 1 & 2 are positive (+) and negative (-) DC power. Pin 3 shuts down the terminal when greater than 2.2VDC is applied
IP-67 rated 6-pin Connector	4 pins used for Ethernet connection. Other 2 pins are not used.
Local Features (behind latch door):	LED status indicator
	USB-Type B for connection to configuration PC
	SIM/USIM Slot
	3.5mm Audio Jack for audio pointing tones
	Function Button – for pointing

Table 1 – Terminal Specifications



Information for Maintenance

In the event that a Hughes 9502 terminal develops a problem, please contact the company that you purchased the terminal from so that they can request an RMA from Hughes for your terminal.

Date of Manufacture

If it is necessary to determine the date of manufacture of a unit, e-mail Hughes at MobileSatelliteSupport@Hughes.com and provide the IMEI from the unit label.

Manufacturer Contact

For other general queries, contact Hughes at:
11717 Exploration Lane, Germantown, MD 20876, USA
+1 (301) 428-5500
www.hughes.com

Chapter 2 Configuration via Web UI

The UT is typically configured via the Web User Interface (UI). Browsers that are currently supported are IE, Edge, Firefox, and Safari. Chrome can be used but does not support downloading files from the Home page.

Web UI Layout

The Web User Interface (UI) is the same as the Hughes 9502 and can be accessed from a MAC or PC browser by entering 192.168.128.100 as the URL (unless you change the IP address of the UT.)

Table 2 shows the Web UI layout:



Home	Connections	Settings	M2M	Security	SMS
Home	Manage Contexts Automatic Contexts Manage APNs	General IP Address / DHCP Ethernet ATC Setup Features	M2M Setup	Security	Send/Receive SMS Saved Drafts Sent Messages

Table 2 – Web UI Layout

Home Tab

The home page includes the following fields:

Terminal Information

- Model
- IMEI
- Software Version

SIM Information

- IMSI
- SIM APN
- Terminal phone number

Troubleshooting

Terminal Log Files: This allows you to extract and save any of the following log files for troubleshooting purposes:

- System Log
- Event Log
- Packet Log

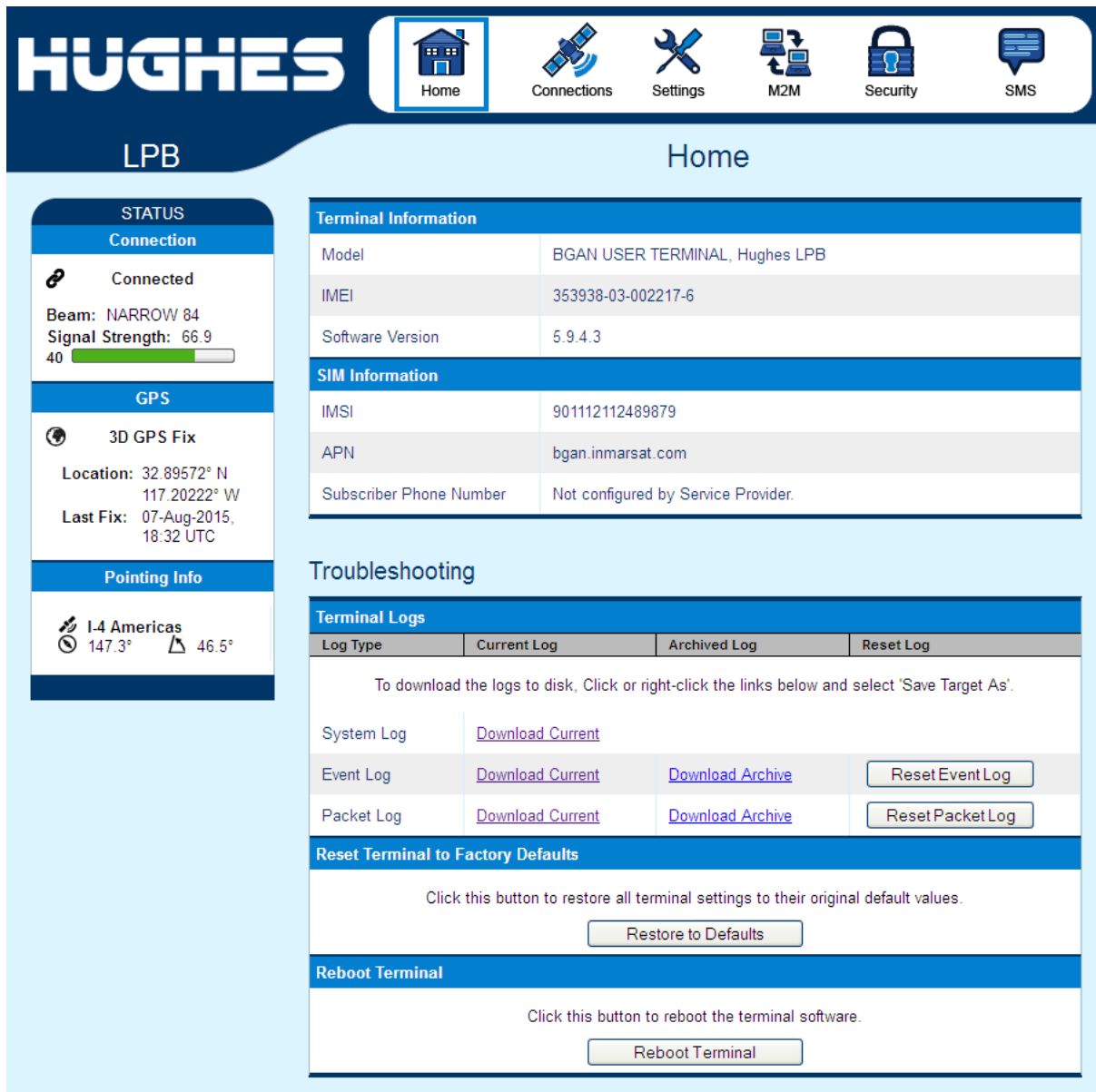

The screenshot shows the Hughes LPB Home Page. At the top, there is a navigation bar with icons for Home, Connections, Settings, M2M, Security, and SMS. The main content area is divided into several sections:

- STATUS:**
 - Connection:** Connected. Beam: NARROW 84. Signal Strength: 66.9 (40%).
 - GPS:** 3D GPS Fix. Location: 32.89572° N, 117.20222° W. Last Fix: 07-Aug-2015, 18:32 UTC.
 - Pointing Info:** I-4 Americas. Azimuth: 147.3°, Elevation: 46.5°.
- Terminal Information:**

Model	BGAN USER TERMINAL, Hughes LPB
IMEI	353938-03-002217-6
Software Version	5.9.4.3
- SIM Information:**

IMSI	901112112489879
APN	bgan.inmarsat.com
Subscriber Phone Number	Not configured by Service Provider.
- Troubleshooting:**
 - Terminal Logs:**

Log Type	Current Log	Archived Log	Reset Log
System Log	Download Current		
Event Log	Download Current	Download Archive	<input type="button" value="Reset Event Log"/>
Packet Log	Download Current	Download Archive	<input type="button" value="Reset Packet Log"/>

To download the logs to disk, Click or right-click the links below and select 'Save Target As'.
 - Reset Terminal to Factory Defaults:**

Click this button to restore all terminal settings to their original default values.
 - Reboot Terminal:**

Click this button to reboot the terminal software.

Figure 2-1 - Home Page

These files can be FTPed out of the UT and used for debugging. To download the logs right-click on the “Download Current” link and select “Save Target As”. This uses FTP to retrieve the files from the UT which can be blocked by some security

software such as McAfee. If you encounter problems, check your PC security settings.

When extracting files, clear the browser cache on the computer between each download or the browser may use a cached copy rather than downloading the latest version of the file.

Downloading files is not supported with the Chrome browser.

Status Bar

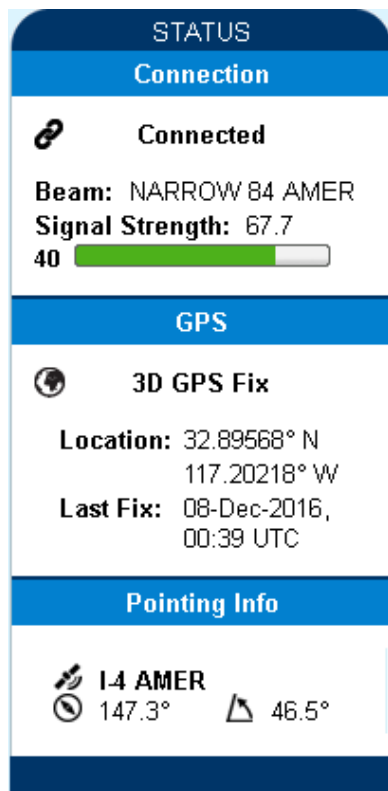

The status bar is included on the home page and other pages that do not have a navigation bar. It includes a field with the elevation angle and compass direction towards the visible satellite(s).

The status text in the *Connection* section is as shown in Table 3 – Status Bar below.

Display	Comments	Corresponding LED display
Initializing	Initial start up (~15-20 secs)	Various
Pointing	UT in pointing mode	All three LEDs flash 1Hz
Registering	Attempting to register - pointing mode exited or bypassed	PWR on, GPS on or flashing, NET off
Registered	Registered and attached, no context	PWR on, GPS on and NET flashing
Connected	PDP context active	All three on (or off after 1 minute timeout)

Table 3 – Status Bar

The signal strength bar shows the quality of the received signal. The same scale is used for all beam types and so during pointing only the left part of the bar is used. The signal strength in the Global Beam should be 46 to 52dB when it is pointed correctly (the higher the better). It also lists the current satellite beam type and number. In release 5.9.5.0 and higher the current satellite is also shown.

The signal strength increases in value as you transition to the Regional Beam and again when you get a PDP context and transition to the Narrow Beam.

The *GPS* status area shows the status of the GPS fix and results are shown in the following table:

Display	Comments
Acquiring	Trying to acquire a GPS fix
Stored	UT is using a Stored GPS fix
2D GPS Fix	The UT has acquired a 2D GPS fix and can continue Registration with the network
3D GPS Fix	The UT has acquired a 3D Fix
Location	Shows Latitude and Longitude coordinates if allowed by network GPS Policy.



	Shows "Blocked" if the unit has a fix but the policy has not yet been received from the network.
Last Fix	Shows date and UTC time of last GPS fix

Table 4 – GPS Status

The *Pointing Info* section shows the satellite that the UT should be pointed to and gives the Azimuth and elevation angles to the satellite. When the UT is in an overlap region, the Pointing Info section will show both satellites and the user will have to pick the best one to point to.

In release 5.9.5.0 and above, a pointing control button was added to the Home page that duplicates the function button on the UT. During the "wait for input" state at startup this button is active for 15 seconds. If pressed the UT will enter pointing mode and remain until the button is pressed again. This feature is useful for re-pointing without opening the enclosure.

Connections Tab

Manage Contexts Page

The Manage Contexts page under the Connections tab displays the status of any active contexts and allows contexts to be controlled. Typically this page will not be used and you configure context activation via the always on option on the M2M page or the ACA page.

Note, in NAPT mode the PDP context will NAPT data for all devices on the LAN. The owner IP address is shown as “shared”.

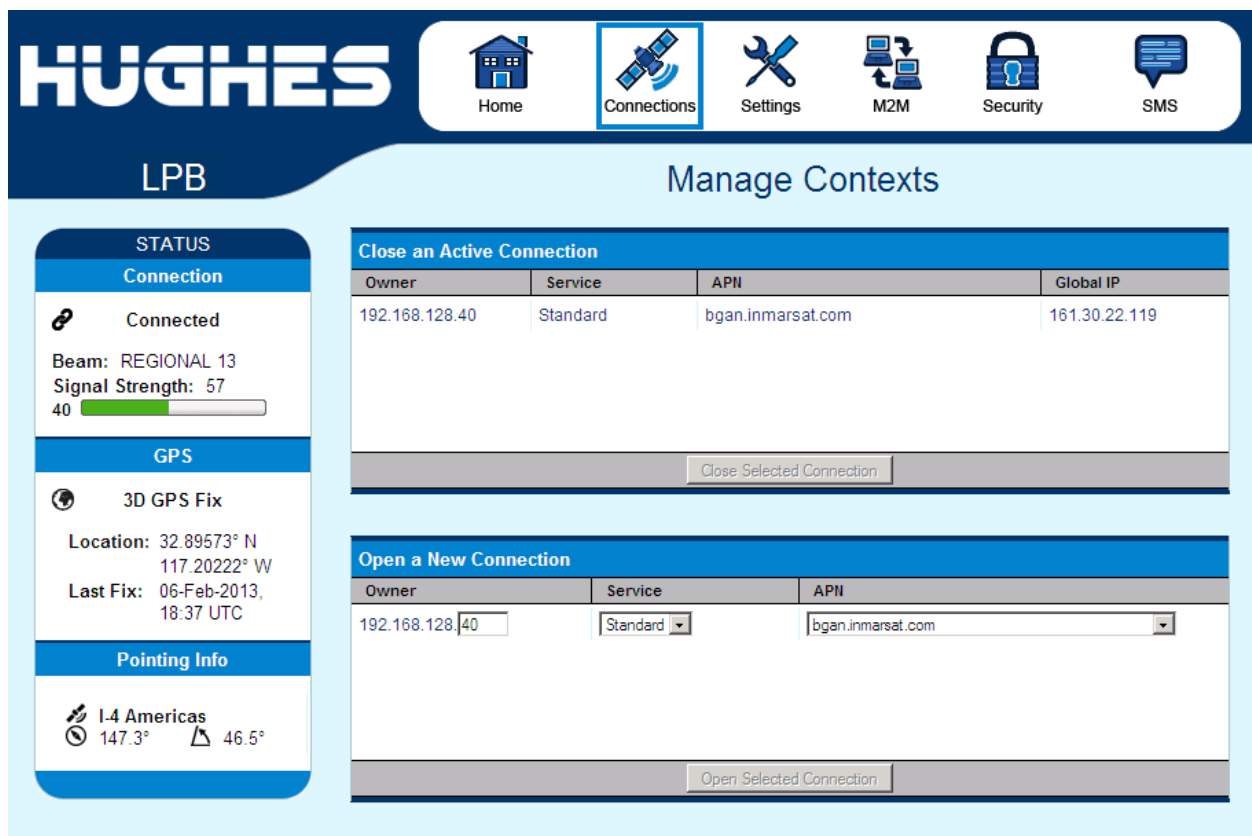

The screenshot shows the 'Manage Contexts' page in the LPB interface. The top navigation bar includes Home, Connections (highlighted), Settings, M2M, Security, and SMS. The left sidebar shows 'LPB' and various status indicators.

STATUS

Connection

Connected

Beam: REGIONAL 13
Signal Strength: 57
40

GPS

3D GPS Fix

Location: 32.89573° N
117.20222° W
Last Fix: 06-Feb-2013,
18:37 UTC

Pointing Info

I-4 Americas
147.3° 46.5°

Close an Active Connection

Owner	Service	APN	Global IP
192.168.128.40	Standard	bgan.inmarsat.com	161.30.22.119

Close Selected Connection

Open a New Connection

Owner	Service	APN
192.168.128.40	Standard	bgan.inmarsat.com

Open Selected Connection

Figure 2-2 – Manage Contexts

Automatic Contexts

This web page allows you to use Automatic Context Activation (ACA) for multiple devices. (The M2M page Always on context can be used if you only require a single context.) The ACA page is not available in NAPT or PPPoE modes.

Static IP Automatic Contexts: You can define static ACA entries for specific addresses. If an entry is set to “On”, the UT will set up a context for this address at startup, regardless of whether it sees it. If set to “Data”, the UT will activate the context when it sees data from the device destined to the space link.

If the context is deactivated by the network, e.g. due to inactivity, the UT will reactivate it.

To turn on ACA for a particular static address, select “On” or “Data” from the drop down list and enter an address.

When you are finished, click on **Update Static Settings** and you should see a message saying “Operation Successful”.

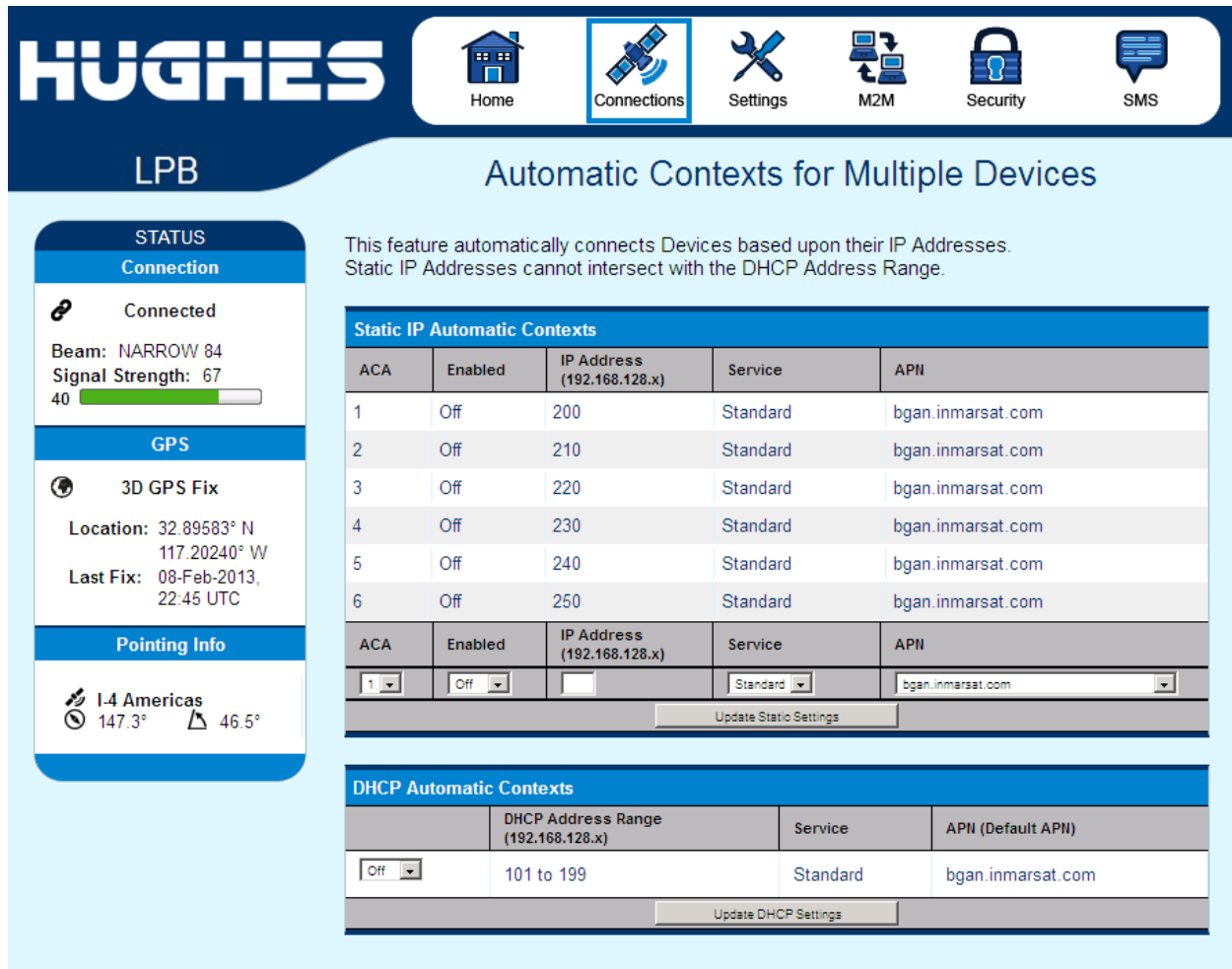



Home

Connections

Settings

M2M

Security

SMS

LPB Automatic Contexts for Multiple Devices

STATUS

Connection

Connected

Beam: NARROW 84
Signal Strength: 67
40

GPS

3D GPS Fix

Location: 32.89583° N
117.20240° W
Last Fix: 08-Feb-2013,
22:45 UTC

Pointing Info

I-4 Americas

147.3° 46.5°

This feature automatically connects Devices based upon their IP Addresses. Static IP Addresses cannot intersect with the DHCP Address Range.

Static IP Automatic Contexts				
ACA	Enabled	IP Address (192.168.128.x)	Service	APII
1	Off	200	Standard	bgan.inmarsat.com
2	Off	210	Standard	bgan.inmarsat.com
3	Off	220	Standard	bgan.inmarsat.com
4	Off	230	Standard	bgan.inmarsat.com
5	Off	240	Standard	bgan.inmarsat.com
6	Off	250	Standard	bgan.inmarsat.com

ACA	Enabled	IP Address (192.168.128.x)	Service	APII
1	Off		Standard	bgan.inmarsat.com

DHCP Automatic Contexts			
	DHCP Address Range (192.168.128.x)	Service	APII (Default APII)
Off	101 to 199	Standard	bgan.inmarsat.com

Figure 2-3 – Automatic Contexts

DHCP Automatic Contexts: This option allows you to set up the UT for dynamic ACA. This means that any device connected to the UT via **DHCP** will automatically receive a standard context.

To activate this feature, select “On” or “Data” from the drop down list under **DHCP Automatic Contexts** section. The APN will be the default APN configured on the **Manage APNs** page.

HUGHES Home Connections Settings M2M Security SMS

LPB Automatic Contexts for Multiple Devices

This feature automatically connects Devices based upon their IP Addresses. Static IP Addresses cannot intersect with the DHCP Address Range.

Static IP Automatic Contexts				
ACA	Enabled	IP Address (192.168.128.x)	Service	APN
1	On	200	Standard	bgan.inmarsat.com
2	Off	210	Standard	bgan.inmarsat.com
3	Off	220	Standard	bgan.inmarsat.com
4	Off	230	Standard	bgan.inmarsat.com
5	Off	240	Standard	bgan.inmarsat.com
6	Off	250	Standard	bgan.inmarsat.com

ACA	Enabled	IP Address (192.168.128.x)	Service	APN
1	On	200	Standard	bgan.inmarsat.com

Update Static Settings

DHCP Automatic Contexts			
	DHCP Address Range (192.168.128.x)	Service	APN (Default APN)
Data	101 to 199	Standard	bgan.inmarsat.com

Update DHCP Settings

Figure 2-4 – DHCP Automatic Contexts

Once you hit “Apply” you will get a pop-up message saying that the ACA settings were updated successfully and to take effect you will have to reboot the terminal.

Once you reboot the terminal, check that the settings took effect.

To see if the context has been setup properly, click on the **Connections** tab>**Manage Connections** Page and this will show you all contexts that have been setup (active or inactive).

Manage APNs Page

The Manage APNs page under the Connections tab allows the user to view the available APNs and define new ones, e.g. if the correct APN is not configured in the SIM.

To make an APN the default, select it in the Defined APNs list and press “Make Default”. The selected APN will be moved to the top of the list and shown in bold font. If an Always on Context is already defined, you must manually update the configuration on the M2M page to change to the new APN.

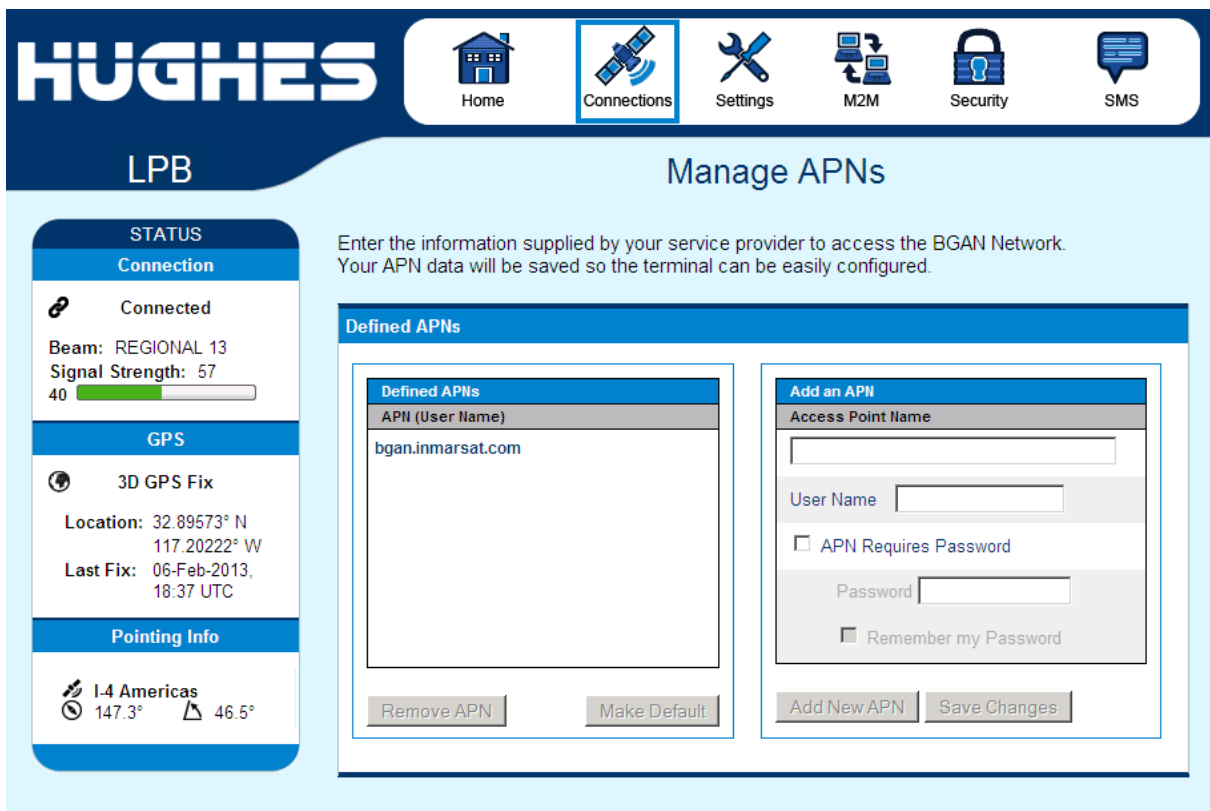

The screenshot displays the 'Manage APNs' interface. On the left, the 'STATUS' section shows the device is 'Connected' with a signal strength of 40. It also displays GPS coordinates (32.89573° N, 117.20222° W) and pointing information for 'I-4 Americas' (147.3° azimuth, 46.5° elevation). The main area is titled 'Manage APNs' and contains a 'Defined APNs' list with one entry: 'bgan.inmarsat.com'. Below this list are 'Remove APN' and 'Make Default' buttons. To the right is the 'Add an APN' form, which includes an 'Access Point Name' field, a 'User Name' field, a 'Password' field, and checkboxes for 'APN Requires Password' and 'Remember my Password'. 'Add New APN' and 'Save Changes' buttons are at the bottom of the form.

Figure 2-5 – Manage APNs

Add an APN field – Use this field to add an additional APN that you want to use, or to edit an existing APN. For adding a new APN, type in the new APN and username (if required) then select **Add New APN**. If the APN requires a password, select the “APN Requires Password” box. If you want to save the password so you don’t have to re-type it each time you configure a PDP context for that APN, check the “Remember my Password” box and then click the **Add New APN** button. (The username is always saved if entered.) The new APN name will show up in the **Defined APNs** field with the username in parentheses. This APN will now be available to use from any APN drop down menu.

Settings Tab

The settings tab has the following configuration pages:

General Setup

Release 5.9.5.0 on includes a General Setup page with the following fields:

- Connection:** this field controls the satellites the UT will try to connect to. With the default “Automatic” selection it will search for all satellites.
 If an individual satellite is selected the UT will only search for and use the selected satellite. This is useful in areas where the antenna can see two satellites at the same time, e.g. EMEA and MEAS from Europe and West Africa – see . During site switches, the satellite signal is turned off briefly and the UT may try to register on the other satellite it can see. The signal will be weaker and will degrade service, so it is advisable to configure the UT to only use a single satellite. The visible satellites are shown on the status bar of the Home page.
- Streaming Inactivity Timer.** In 9502B (BGAN Services) mode, a streaming inactivity timer field is also displayed. By enabling this parameter, the user can turn on a timer for inactivity on streaming contexts. The timer is in either seconds or minutes and will tear down a streaming context after X seconds or minutes of inactivity.

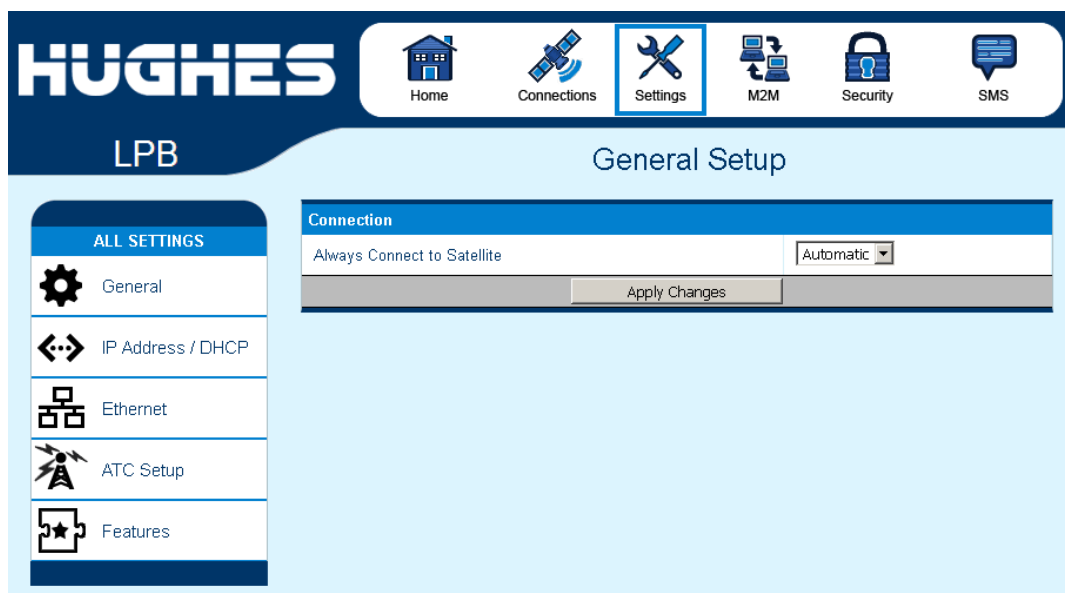

Figure 2-6 – General Setup

IP Address/DHCP Settings

The IP settings page under the Settings tab includes the following fields:

- Terminal Local IP address
 - Allows you to change the UT's IP address
 - In PPPoE mode with the Inmarsat NSD you typically set the UT IP address to 192.168.0.1. If two BGAN terminals are connected to the NSD, set the IP address of the second UT to 192.168.0.129.
- Subnet Mask Range (release 5.9.5.3)
 - Only used in PPPoE mode. If two BGAN terminals are connected to the NSD, set to 255.255.255.128
- Default route IP address (release 5.9.5.3)
 - Only used in PPPoE mode. Use with the NSD when the TE local subnet is different from the UT subnet.
- DHCP Server enable
- DHCP Address Range
- Lease Time when Idle
- Lease Time when Connected
 - If operating with a Vodafone MachineLink, recommend setting to a large value such as 1440 minutes, or use Static addressing.
- Network Mode field: NAT, NAPT, Relay or PPPoE mode (see Network Mode section.)
- Relay Connected Mode Subnet Mask (release 5.9.5.3)
Defaults to 255.255.0.0. Can be used to configure a different subnet mask in Relay mode. Only applied when the Relay mode PDP context is active.

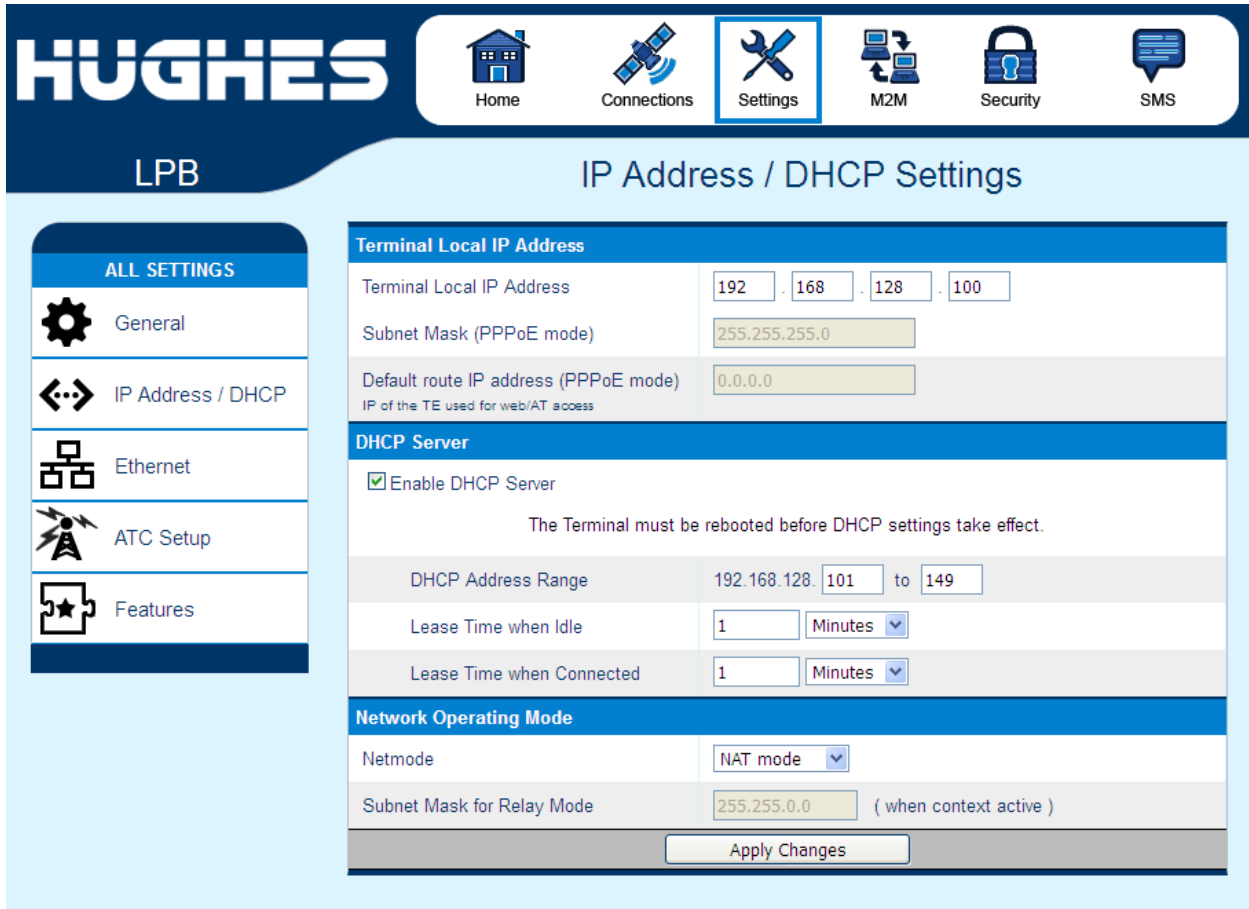

Figure 2-7 – IP Address/DHCP Settings

Ethernet Port Page

The Ethernet Port settings page includes:

- Wake On LAN (see Wake on LAN (Any Packet section)):
 - Wake On LAN – On/Off radio button
 - Wake On LAN idle timer – in minutes
 - Wake On LAN time of day – 24 hour clock
- MAC Address filtering:
 - Ethernet MAC Address filtering enable tick box
 - Table of allowed Ethernet MAC addresses.
- Ethernet Operation: Duplex Mode
 - In Default mode, the UT uses Half Duplex, except in Netmode PPPoE when it automatically uses Full Duplex for operation with the Inmarsat NSD.
 - Full or Half Duplex option can be used in the unusual case that the default setting is not correct for your application.

Note that the UT does not support duplex negotiation and so Full Duplex can only be used in the rare case that the TE device is also configured for Full Duplex, no negotiation.

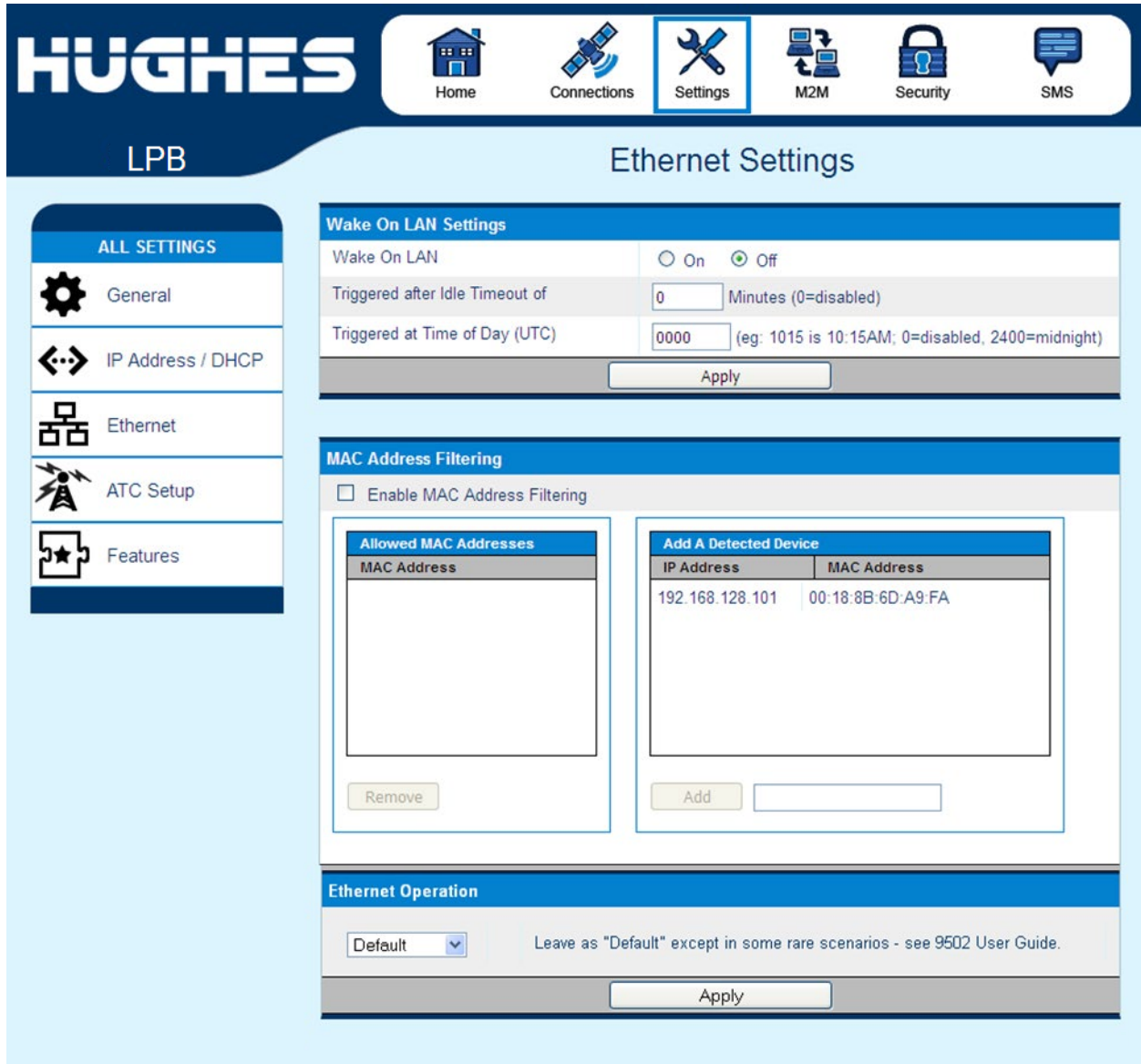

HUGHES

Home Connections **Settings** M2M Security SMS

LPB Ethernet Settings

ALL SETTINGS

- General
- IP Address / DHCP
- Ethernet
- ATC Setup
- Features

Wake On LAN Settings

Wake On LAN On Off

Triggered after Idle Timeout of Minutes (0=disabled)

Triggered at Time of Day (UTC) (eg: 1015 is 10:15AM; 0=disabled, 2400=midnight)

Apply

MAC Address Filtering

Enable MAC Address Filtering

Allowed MAC Addresses	
MAC Address	

Remove

Add A Detected Device	
IP Address	MAC Address
192.168.128.101	00:18:8B:6D:A9:FA

Add

Ethernet Operation

Default Leave as "Default" except in some rare scenarios - see 9502 User Guide.

Apply

Figure 2-8 – Ethernet Settings

Port Forwarding Page

The Port Forwarding page is only available in NAPT mode and includes:

- DMZ – if enabled, all packets received from the space link that are not routed to other addresses will be forwarded to the DMZ host address.
- Port Forwarding Rules. These fields allow you to configure rules defining how packets of particular protocols are routed, e.g. TCP port 80 for HTTP. Port Forwarding rules are applied before the DMZ rule.

The screenshot shows the Hughes LPB Port Forwarding settings page. At the top, there is a navigation bar with icons for Home, Connections, Settings, M2M, Security, and SMS. Below this, the page is titled 'LPB Port Forwarding'. On the left, there is a sidebar with 'ALL SETTINGS' and options for IP Address / DHCP, Port Forwarding (selected), Ethernet, ATC Setup, and Features. The main content area is divided into two sections: 'DMZ Configuration' and 'Port Forwarding Rules'.

DMZ Configuration

Enable DMZ Host

DMZ Host IP Address: 192.168.128.101

Apply Changes

Port Forwarding Rules

Rule	Enabled	Global Port	Protocol	Local IP (192.168.128.x)	Local Port
1	Off	0	TCP	0	0
2	Off	0	TCP	0	0
3	Off	0	TCP	0	0
4	Off	0	TCP	0	0
5	Off	0	TCP	0	0

Update Port Forwarding Rules

Figure 2-9 – Port Forwarding Settings

ATC Page

The ATC page includes:

- ATC robustness On/Off radio button
- ATC scan button
- ATC scan status bar. This indicates the results of the last scan.

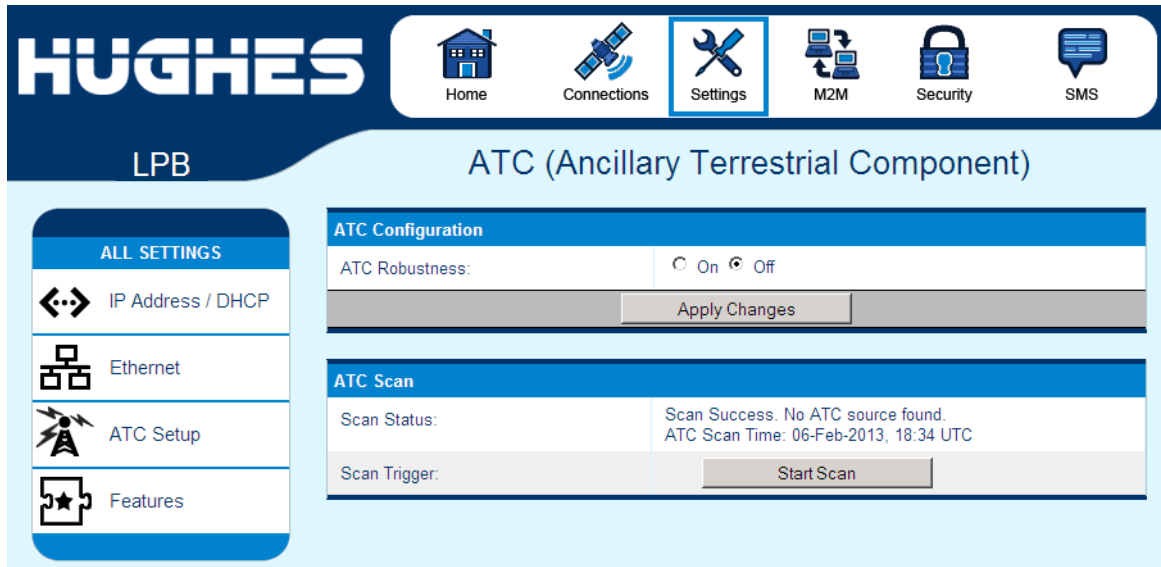
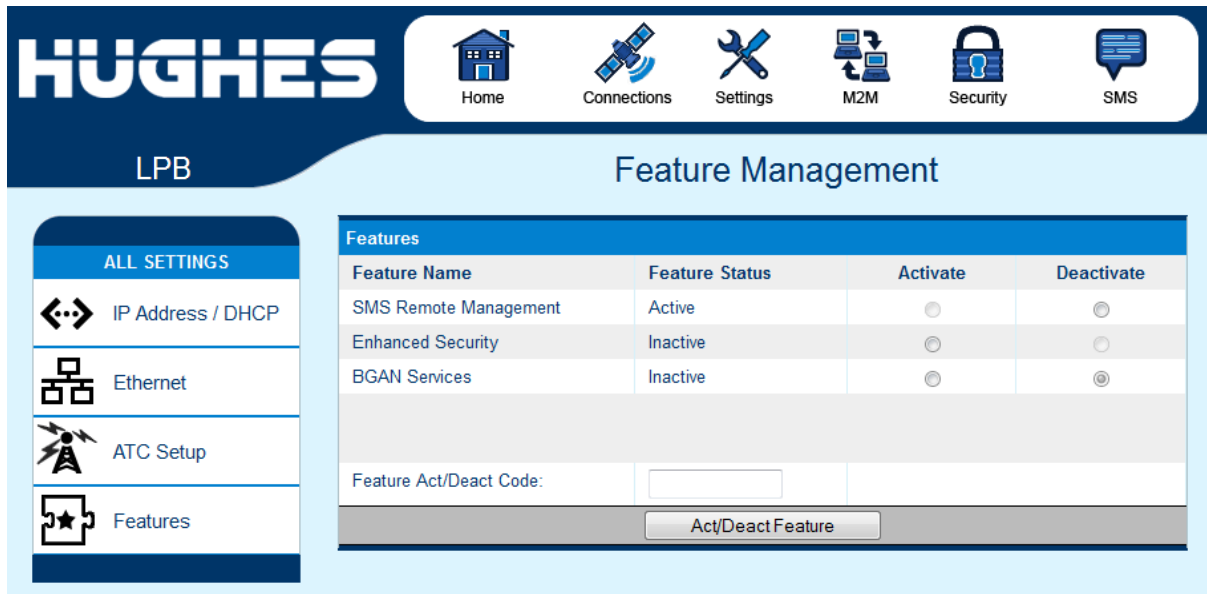

Figure 2-10 – ATC Page

Feature Management Page



The screenshot shows the Hughes LPB interface. At the top, there is a navigation bar with the Hughes logo and icons for Home, Connections, Settings, M2M, Security, and SMS. Below this, the 'Feature Management' section is displayed. On the left, there is a sidebar with 'ALL SETTINGS' and options for IP Address / DHCP, Ethernet, ATC Setup, and Features. The main area contains a table of features and their status.

Feature Name	Feature Status	Activate	Deactivate
SMS Remote Management	Active	<input type="radio"/>	<input checked="" type="radio"/>
Enhanced Security	Inactive	<input checked="" type="radio"/>	<input type="radio"/>
BGAN Services	Inactive	<input checked="" type="radio"/>	<input type="radio"/>

Below the table, there is a 'Feature Act/Deact Code:' field with an input box and an 'Act/Deact Feature' button.

Figure 2-11 – Feature Management Page

You can enable special features from this page:

SMS Remote Management allows the unit to receive and act on special remote control SMS messages. This feature is on by default.

Enhanced Security allows you to lock the UT so that it can only be accessed locally after entering a password. Refer to the Enhanced Security Settings Page below. When this feature is active, the remote SMS password will be stored encrypted. When the feature is enabled a link to the Enhanced Security page appears on the Security Passwords page (see below).

BGAN Services allows the unit to be converted to a unit that uses a BGAN rather than an M2M SIM.

With release 5.9.4.3 and above, the features can be deactivated with the same code used to activate them. Select the deactivate radio button and press Act/Deact Feature.

With release 5.9.5.1 and above, the UT will automatically switch between M2M and BGAN Services based on the type of SIM card. The Feature code is no longer required.

M2M Page

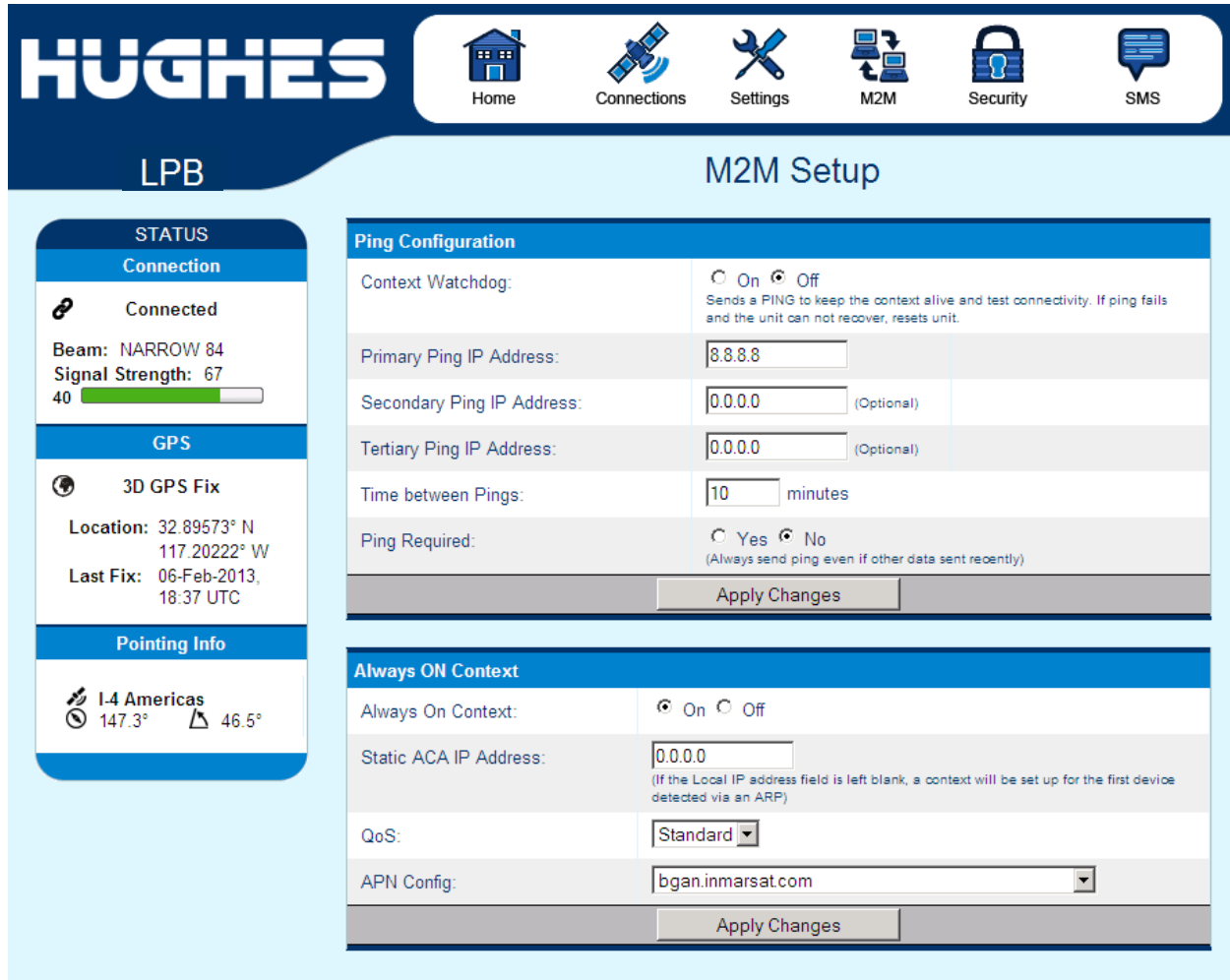

Figure 2-12 – M2M Setup

The M2M page includes the following configurable parameters:

Ping Configuration:

- Context Watchdog - On/Off
- Primary Ping Address
- Secondary Ping Address
- Tertiary Ping Address
- Time between Pings
- Ping required - Yes/No. If set to “No”, then the system will not try to ping on timer expiration if data was transmitted within the watchdog period.

Always On Context:

- Always on context - On/Off (default is On)
- Always on static IP address. If the TE has a known static IP address or never ARPs, enter this address. Alternatively, leave the IP address blank (0.0.0.0) and the UT will set up a context for the first device it detects through ARP during startup.
- APN drop down box. This includes the APNs configured on the Manage APNs page and (in release 5.9.5.2 and above) the “Use a network assigned APN” option. This option allows the network to assign the APN rather than the user configuring it at the UT. It should only be used if this option is appropriately configured at the network side.

Security Passwords

The security passwords page includes the following functions:

- Personalization Key to lock the UT to a particular USIM (SIM to Phone lock). This is Off by default.
- Administration password – Off by default. Default password is **admin**
- SMS Remote Control – **On** by default in 5.9.4.3 and above. On/Off radio button
- SMS Remote Password – default is **remote** (case sensitive)
- Sender White-list – is a list of numbers that the terminal will allow a remote SMS message to come from. When entering the number use the + symbol in front of the country code e.g., +870 or just start with the country code e.g., 870. Do not use 00 in front of the country code.



HUGHES LPB Security Passwords

STATUS

Connection

Registered

Beam: REGIONAL 13
Signal Strength: 57
40

GPS

2D GPS Fix

Location: 32.89572° N
117.20225° W
Last Fix: 20-Dec-2011,
22:39 UTC

Pointing Info

14 Americas
147.3° 46.5°

Remote SMS Feature

Remote SMS Control On Off

Remote SMS Password: remote

Senders White-list
(List of Allowed Remote-SMS Senders)
If configured, ONLY Remote-SMS messages from this list of Senders will be honoured.
Note: Substitute '+' for any leading zeros in the MSISDNs entered.

-	-
-	-
-	-
-	-
-	-
-	-

Apply

Administration Password

Administration Password has not been Created [Change Settings...](#)

Phone-to-SIM PIN

A Phone-to-SIM PIN (up to 8 digits) can be used to lock the terminal to the installed SIM. The terminal will require the Phone-to-SIM PIN before another SIM can be used.

Phone-to-SIM PIN is Disabled [Change Settings...](#)

Figure 2-13 – Security Passwords

If the Enhanced Security feature is enabled, a link to the Enhanced Security page will be displayed as shown below.

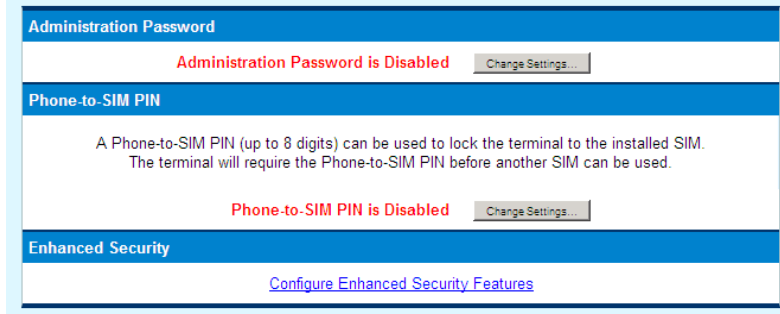

Figure 2-14 – Enhanced Security Page Link

Enhanced Security Settings Page

The Enhanced Security Page is used to configure local security for the unit.

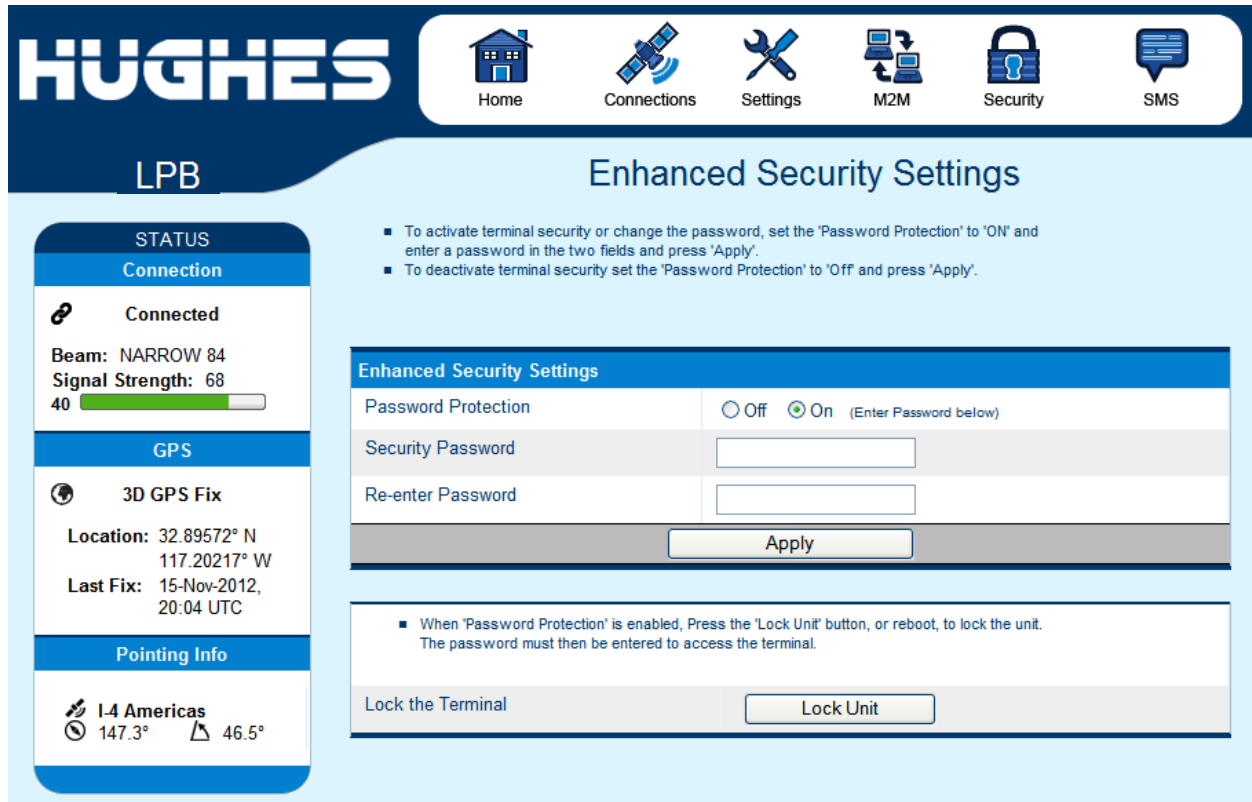

Figure 2-15 – Enhanced Security Settings Page

For added security you can lock the UT so that it cannot be accessed locally. This is controlled by a security password configured from the Enhanced Security Settings page accessible from the Security Passwords page.

When the password is active, each time the UT starts up, the password must be entered before the user interface can be

accessed. All local IP ports are blocked, e.g. so AT commands, and the upgrader cannot be used. User data can be sent if a PDP context is up.

To activate the security feature, select “Password Protection” On, enter the same password string in both fields and press “Apply”. If the two password fields match, the password is saved and security is enabled.

The UT will be locked when it restarts, or to immediately lock it, press “Lock Unit”

Make a note of the password as it cannot be viewed and once the UT is locked it cannot be accessed.

To deactivate the security feature, select “Password Protection” Off and press “Apply”.

If the Web UI is accessed when the UT is locked, the browser is redirected to the Login page and the password must be entered. If the wrong password is entered three times in a row, password entry is locked out and the UT must be restarted before the password will be accepted.

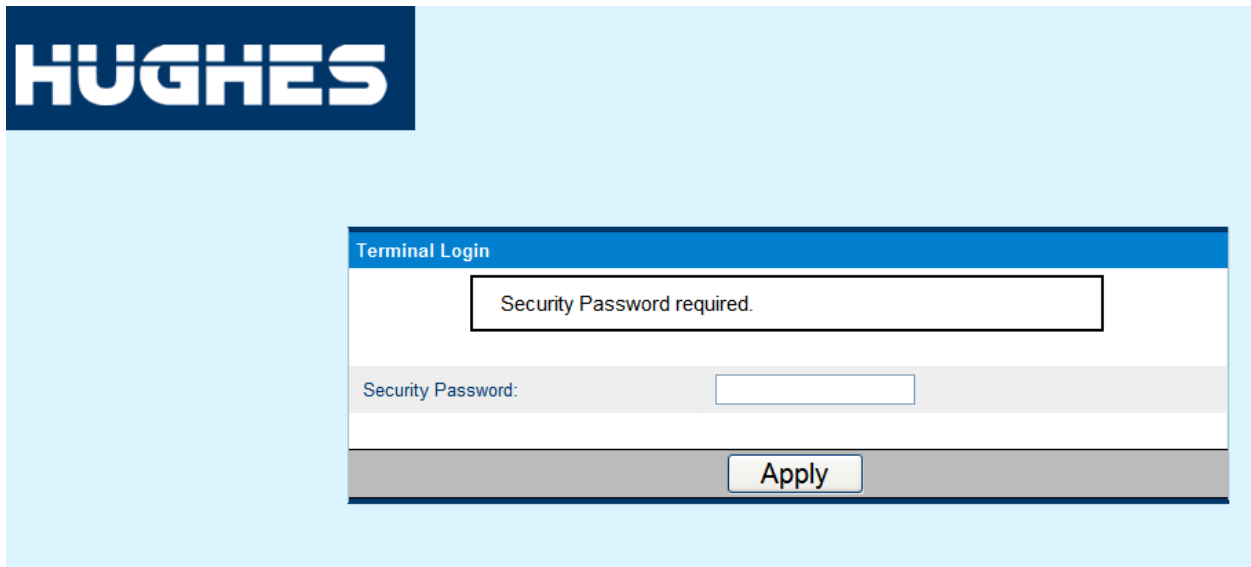

Figure 2-16 – Login Page

SMS Pages

The SMS pages are used to send SMS messages from the terminal to another BGAN device or another phone number. When sending an SMS message, use the + symbol in front of the country code of the number you want to send the SMS to e.g., +18005551234.

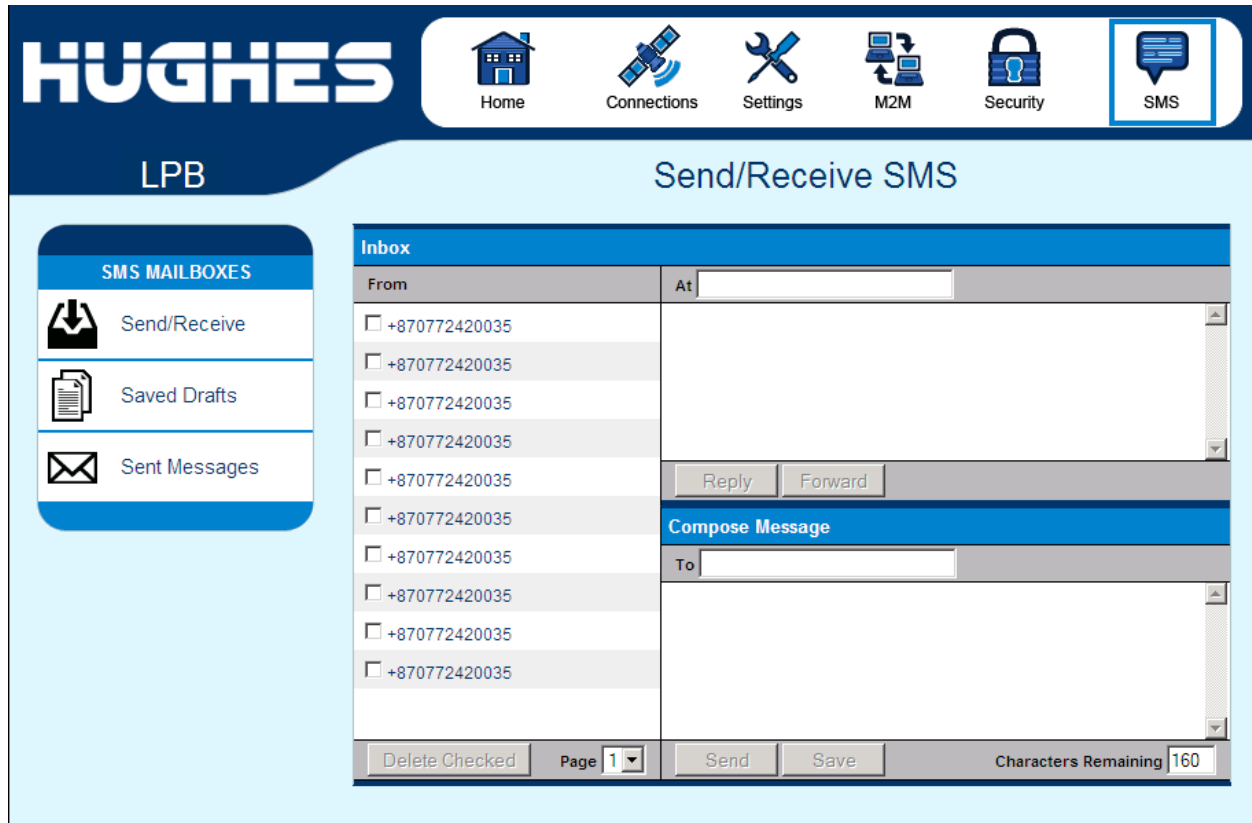

Figure 2-17 – SMS Send/Receive

Chapter 3 Operational Features

LEDs

The LPB unit has three green LEDs:

Power LED: “PWR”

- Turn unit on - LED turns on

“GPS” LED

- Flashes while acquiring fix
- Turns solid when unit has a 2D or 3D fix

Network LED: “NET”

- Flashes when registered
- Turns solid when unit establishes a PDP context

All three LEDs flash in install mode and short flash if there is a fault detected that prevents normal operation, e.g. no SIM installed or incorrect SIM installed.

Function Button

The LPB unit includes one user button called the “function” button.

- Short press (< 2 second):
 - During startup while power LED flashing, a short press enters install mode (see Pg 39.)
 - In install mode, short press exits install mode
 - If LEDs off, short press turns them on
- Medium press (2 to 5 seconds – the user should press and hold for about 3 seconds):
 - Shut down and reboot
- Long press (> 5 seconds):
 - Hardware power cycle

Network Mode

By default the LPB is configured for NAT mode in the Network Mode field on the IP Address/DHCP settings page.

NAT Mode

In **NAT mode** once a PDP context is active, the UT will translate between the local and global IP addresses. This is a basic NAT that only performs IP address translation. It does not use port translation.

NAPT Mode

In **NAPT mode** (5.9.4.4 and above) multiple devices connected via a hub or switch share a single PDP context. The port translating NAT modifies both IP addresses and port numbers so multiple devices can share the single global IP address assigned to the PDP context.

In NAPT mode only a single context is supported. By default the Always On Context is activated on the M2M page. The ACA page is removed. A Port Forwarding page is added under Settings and can be used to configure the DMZ and Port Forwarding rules.

Relay Mode

In **Relay mode** the UT will supply the global IP address to the TE when the context is established. Relay mode is single user and only supports a single connected TE.

In Relay mode DHCP is required to provide the global IP address to the TE. When the context is activated, the DHCP server in the UT will NACK the next DHCP lease renewal from the TE and assign the global IP address assigned by the network. The local IP connection will be torn down and reestablished as the IP address changes. Similarly, when the context is deactivated the DHCP server will NACK the lease renewal and then reassign the original private IP address.

The Web UI will lose and reestablish its connection to the terminal as the IP address is changed.

To make the IP address change happen quickly a short DHCP lease should be used. The terminal defaults the lease time to 60 seconds in idle and connected mode.

NOTICE

Relay mode only supports a *single* user TE. If you need to connect a laptop via the USB port for configuration and monitoring purposes, you must set the laptop up with a local static IP address within the same subnet as the terminal e.g., 192.168.128.200. This prevents the USB port from getting the single DHCP address when in Relay mode once you reboot the terminal.

PPPoE Mode

In **PPPoE mode** (release 5.9.5.3 and above) the UT uses PPP over Ethernet to communicate with the TEs. PPP sessions are mapped to PDP contexts. PPPoE mode is primarily designed to operate as a backup path for the Inmarsat Network Service Device (NSD). Refer to the Inmarsat NSD documentation for details.

The NSD requires the UT to be configured for 10BaseT Full Duplex. When PPPoE mode is selected, the UT will automatically set the Ethernet port to Full Duplex. If PPPoE is used with another device not hard configured for full duplex, manually select Half Duplex on the Ethernet Settings page.

With the NSD you typically set the UT IP address to 192.168.0.1 on the IP settings page. If two BGAN terminals are connected to the NSD, set the subnet mask to 255.255.255.128 on both UTs and set the IP address of the second UT to 192.168.0.129.

If the TEs use a subnet other than the directly connected interface range, configure a default route on the IP Settings page so that the WebUI can be accessed. The default route will be in the subnet associated with the TE Ethernet interface.

If you need to reconfigure a UT out of PPPoE mode back to NAT mode, it may be easiest to first Reset Factory Defaults from the Home page.

Remote Control

The LPB can be controlled remotely via SMS and locally via AT commands. The AT interface can be used for local control of the terminal as long as AT commands can be sent by the terminal equipment (TE) connected. The syntax of all AT commands is covered in the “Inmarsat BGAN UT-TE Interface Specification” and the AT command listing supported by the LPB can be downloaded from the Hughes website at bgan.hughes.com.

The LPB includes a remote control by SMS feature that supports the special SMS messages listed in Table 5 – Remote Control SMS Message Commands. Remote control SMS is supported by default in the LPB and does not have to be activated by a feature code. The syntax of the messages is covered in the “Hughes 9502 SMS Remote Control Feature User Guide.”

All remote control messages and responses must fit into a single 160 character SMS.

The SMS handler automatically deletes any message that fills the last SMS slot in the USIM to ensure there is always room to

receive control SMS messages. Control messages are received into the SIM then read out and deleted so as not to fill up the SIM card.

Command	Action
ACTIVATE	Activate PDP context
DEACTIVATE	Deactivate PDP context
CLEAR	Clear SMS messages in the UT SIM
GETINFO	Get info from the UT. This returns an SMS with the information.
RESTART	Restart the UT
WATCHDOG	Change the configuration of the watchdog parameters
ATCO	<p>Execute the AT command encapsulated in the SMS. This can be used for the following remote control functions:</p> <ul style="list-style-type: none"> • Download Firmware • Start Firmware upgrade • Get file • Send file, e.g. log files. • Activate Remote Web access • Perform ATC scan and/or set ATC robustness. • Configure the default APN (release 5.9.4.3 on) • Configure the satellite to use (release 5.9.5.0 on)

Table 5 – Remote Control SMS Message Commands

Remote Upgrade and File Transfer

The LPB includes an FTP client. The operator can send SMS messages or AT commands to command the LPB to send or retrieve files from an FTP server in the network or Internet. This allows the LPB to be upgraded, reconfigured and also allows log files to be sent back to the server. The FTP server can be in the Inmarsat network, e.g. accessible via a free APN for upgrades; or can be outside the Inmarsat network, e.g. accessible via a normal APN for debugging and configuration changes.

The remote upgrade process uses download firmware and firmware upgrade commands (see “Hughes LPB SMS Remote Control Feature User Guide”).

Security

The Web UI includes an admin feature that can be activated from the security page to prevent unauthorized access to the Web UI. Additionally the AT command port is locked by default and the

command: `AT_ICLCK="AD",0,"<admin password>"` must be used to unlock it before AT commands can be used. Both mechanisms use the same password but the AT commands port and each Web UI session use a separate lock and must be individually unlocked.

Support for SMS Remote control is configured from the SMS settings page. Each Remote Control SMS must include the correct password. Remote control SMS containing AT commands will be processed regardless of the Admin setting (they require the feature to be active and the correct SMS password.)

USIM personalization (or "Phone to SIM lock") can be used to lock the UT to a particular SIM.

MAC address filtering on the Ethernet port page allows the user to define the MAC address of TEs authorized to communicate via the Ethernet port. **Note:** The USB port is not included in the MAC filtering and can be used if the proper USB driver is installed on the TE.

NOTICE

It is highly recommended that you DO NOT use the SIM PIN on any unattended installation, because if the unit reboots, it will stop at boot-up and wait for someone to enter the SIM PIN.

Wake on LAN (Any Packet)

The UT includes a special low power mode called Wake on LAN (any packet). From the Web UI you can configure the UT to power down into this mode after a configurable idle timer or time of day.

Wake on LAN operation is configured from the Ethernet Settings page (Figure 2-7 – Ethernet Settings) under the Settings tab. It includes a configurable idle timer to control when the UT shuts down into the Wake on LAN mode. The UT declares the link idle if no packets are received on the Ethernet port within the idle time.

Additionally, the UT can be configured to power down at a configurable time of day. Enter UTC time as 0001 to 2400. Set to 0 to deactivate the time of day feature. Note that the UT waits 5 minutes after startup before it checks the time of day to see if it has to power off.

When the UT powers down into this mode it will disconnect from the BGAN network and monitor the local Ethernet port and power up again if it sees any Ethernet packet (ARP, DHCP, data packet, etc). In this mode the power consumption is less than 10mW when powered from a 12V source. The UT generates Ethernet sync pulses so the TE believes the link is still active.

When an Ethernet packet is detected the UT will power up normally, register and bring up a PDP context (if configured for

ACA.) It takes about 1 minute for the UT to be fully connected to the Inmarsat network.

For this mode to be useful the TE must only send Ethernet packets when it has data to send over the air. Thus, for example, the TE should be configured with a static IP address to avoid periodic DHCP exchanges waking up the UT.

Power Pin Control

The UT can be switched off by applying a voltage to pin C of the power connector port.

If you apply voltage to pin C of the power connector port with pin B as ground, the UT will power down. It will power up when you remove the voltage.

The voltage can be 2.5V to 50V. 12V is the recommended level.

ATC

The UT includes an extended L-band scanning mode to detect Auxiliary Terrestrial Component (ATC) or other sources of external interference. The terminal can be commanded into scanning mode by the Web UI, AT command or SMS command. During the scan the terminal will be offline to the BGAN network and will automatically reboot to return to normal operation.

In scanning mode the terminal measures the received signal strength across the 41MHz of L-band spectrum (1518 to 1559MHz). Once the scan is complete the UT restarts and communicates the results of the scan.

If an interference signature is detected, an attenuator is switched into the receiver path to attempt to make the UT more resilient to ATC interference.

The attenuator setting can be controlled from the Web UI, AT command or remote SMS.

Watchdog

The M2M terminal includes a watchdog mechanism that can be used to periodically verify the UT network connectivity and take action if a problem is detected.

Configuration Parameters are shown in the M2M Page.

Chapter 4 Installation Instructions

Inspecting the parts

NOTICE

When opening the box, please carefully read the instructions before removing the terminal. This is a specially designed box and if not handled correctly, the box cannot be reused for shipment.

Determining where to install the terminal

In order for your terminal to work correctly, the terminal must be installed in a location that provides line of sight to the satellite. Any objects such as building structures or trees may degrade the quality of the satellite signal.

1. Unbox the Hughes LPB terminal and power it up lying flat where it can see the sky.
2. Allow it to get a GPS fix and then check the azimuth and elevation pointing information on the Web UI Home page. As long as the elevation angle is between 30 & 60 degrees, you can just point the antenna to the satellite and lay the antenna flat. If the elevation is outside this range, you can use the wedge that is included in the box to tilt the antenna in order to optimize the signal strength of the antenna (see Pointing the Antenna).

HUGHES



Home

Connections

Settings

M2M

Security

SMS

LPB

STATUS

Connection

 **Connected**

Beam: NARROW 84

Signal Strength: 66.9

40

GPS

 **3D GPS Fix**

Location: 32.89572° N
117.20222° W

Last Fix: 07-Aug-2015,
18:32 UTC

Pointing Info

 **I-4 Americas**

 147.3°  46.5°

Home

Terminal Information

Model	BGAN USER TERMINAL, Hughes LPB
IMEI	353938-03-002217-6
Software Version	5.9.4.3

SIM Information

IMSI	901112112489879
APN	bgan.inmarsat.com
Subscriber Phone Number	Not configured by Service Provider.

Troubleshooting

Terminal Logs

Log Type	Current Log	Archived Log	Reset Log
To download the logs to disk, Click or right-click the links below and select 'Save Target As'.			
System Log	Download Current		
Event Log	Download Current	Download Archive	<input type="button" value="Reset Event Log"/>
Packet Log	Download Current	Download Archive	<input type="button" value="Reset Packet Log"/>

Reset Terminal to Factory Defaults

Click this button to restore all terminal settings to their original default values.

Reboot Terminal

Click this button to reboot the terminal software.

Figure 4-1 – Home Page showing pointing information

Install Ethernet, Power and RF Cables

The Hughes LPB has three connectors that need to be installed:

- Ethernet
- RF
- Power

Connect the 6-pin Amphenol connector on the Ethernet cable to the Amphenol connector on the right of the modem. Connect the RJ45 end of the cable to the user equipment.

Connect one of the RF cables between the TNC connectors on the modem and antenna.

Connect the 3-pin Amphenol connector on the power cable to the power Amphenol connector (middle of the three connectors) on the modem. Connect the banana jacks to the power source (12 to 24V DC). The maximum current draw is 2A at 12V, 1A at 24V.

If required, Pin C can be used to switch the modem off and on as described in the Power Pin Control section.



Figure 4-2 Installing Ethernet, Power and RF Cable



Figure 4-3 Cables Connected: RF, 3-pin and 6-pin respectively

To install the two Amphenol connectors correctly, rotate the inside barrel of the connector clockwise until it clicks into the slots of the receptacle, then rotate the outside of the connector clockwise until the 3 slots align with the 3 pins on the terminal connector. Rotate until the three pins lock and click into place.

Powering up the Hughes LPB



The LPB will power up automatically when DC power is applied. It does not have a power button. By default it will bypass antenna pointing and automatically register, attach and activate a PDP context.

Once you have applied DC power, the terminal goes through a Power-On-Self-Test (POST) that takes approximately 15-20 seconds and then the power LED will start flashing for another 15 seconds. If you want to enter pointing mode, you will need to short press (<2 seconds) the function button within those 15 seconds. If you do not short press the Function button, the unit will start to register with the network and set up a PDP context.

 **CAUTION**



If the unit bypasses antenna pointing and starts to register with the network, the unit is now transmitting so please stay at least 1 m clear of the front of the antenna to avoid RF radiation.

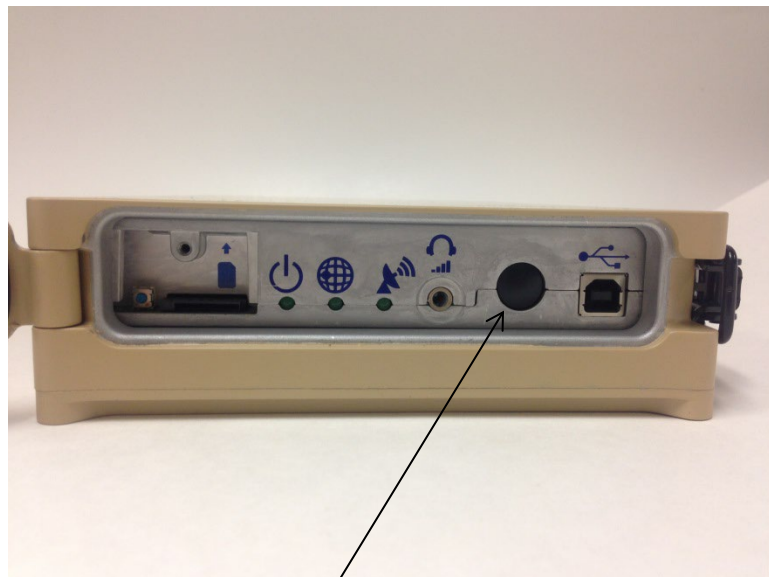

Figure 4-4 - Function Button

Coverage Map

The Inmarsat BGAN service is operated via 4 satellites with global coverage shown below.

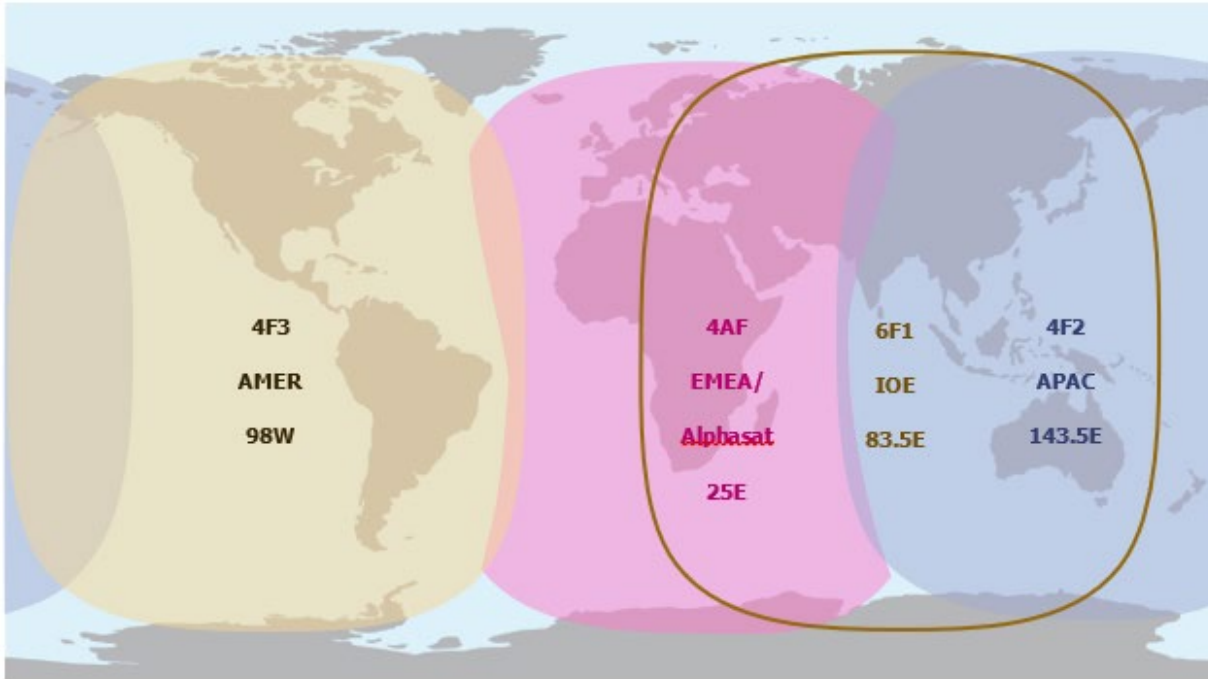

Figure 4-5 Inmarsat Satellite Coverage

NOTICE

In the past there was an issue in some parts of the world where UTs could see both MEAS and EMEA. During outages or site switches when the satellite signal was briefly turned off, the UT could get locked on the other satellite. The fix was to configure the UT to only use the satellite it was pointed at. MEAS has been replaced with IOE which is further away from EMEA which means this problem should no longer occur. However, if the look angle to second satellite is within 60 degrees of azimuth or elevation of the first, it is advisable to configure the UT to only use the satellite it is pointed at.

The visible satellites are shown on the status bar of the Home page. To configure the UT to use a single satellite, use the Connection field on the General Setup page - see page 16. Alternatively, use the `_IHSET="SAT_SELECT"` remote control SMS to configure the satellite.

Pointing the Antenna



Determine compass direction of the satellite in advance of the installation by using the approximate latitude and longitude of the site in a simple satellite pointing application or specially marked map.

Alternatively, you can get the compass direction and elevation angle by powering up the UT, allowing it to get a GPS fix and then checking the pointing information on the LPB home Web UI page.

In order to speed up getting the initial GPS fix, while you are in pointing mode you should lay the unit flat with a clear view of the sky first so that it can see as many GPS satellites as quickly as possible. Once you get the initial GPS fix (open the front door and the GPS LED should be solid green), then you can position the unit as required.

If you short press the function button to enter pointing mode, all three LEDs start to blink, indicating that the terminal is in pointing mode.

To aid in pointing, you can use two different methods:

1. You can use the 3.5mm jack to connect stereo speakers or a headset in order to hear the tones for pointing. As the signal strength increases, the tone pitch will get higher and faster.
2. You can also use the 3.5mm jack to connect a 3.5mm stereo plug that has two bare wires exposed. Touching the two exposed wires with voltmeter leads will give voltage readings from 2.5V to 3.2V as you are pointing. The higher the voltage the better the antenna is pointed. A voltage reading of approximately 2.9V equates to a good signal level of 50dB.

You can also monitor the signal strength by hooking up a laptop/PC to the USB port and monitor it from the Web UI (see Figure 4-1). Access the Web UI by opening a browser (Firefox, Safari, IE or Edge) and typing in the local IP address of the terminal 192.168.128.100

If the pointing elevation of the satellite is between 30 and 60 degrees, lay the antenna flat and point the arrow on top of the antenna in the compass direction of the satellite. If your elevation angle is outside this 30° - 60° range, the pointing wedge can be used to increase or decrease the look angle by 30 degrees if used at the edge of the antenna as shown in the figures below.

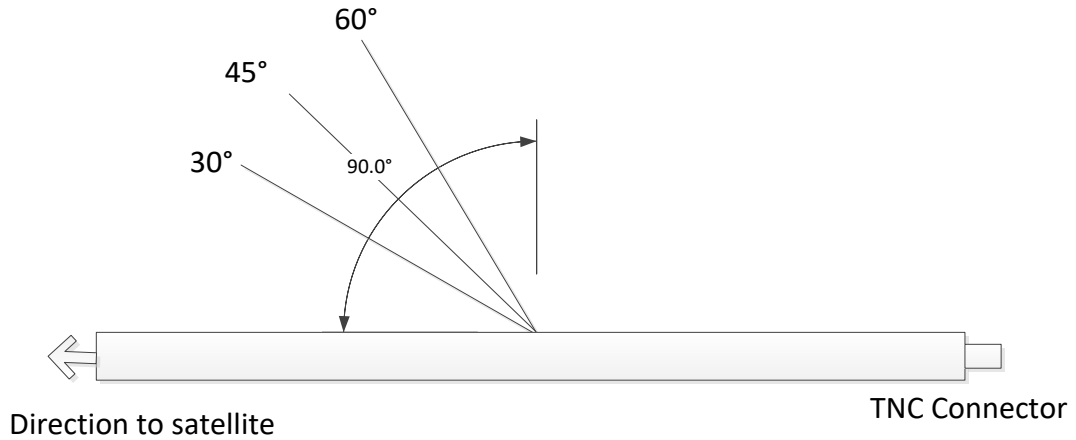

Figure 4-6: Typical Lay Flat Antenna Pointing 30° - 60° Elevation Angle

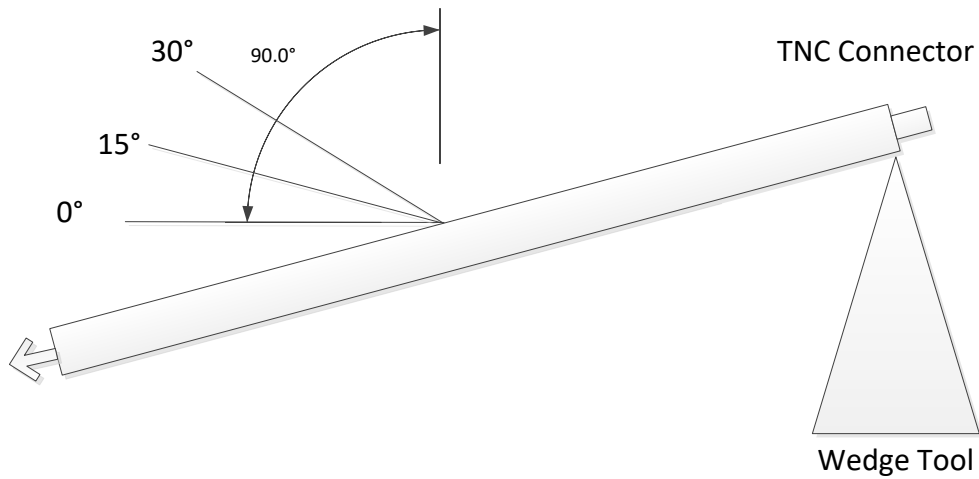

Figure 4-7: 0° to 30° Elevation Angle

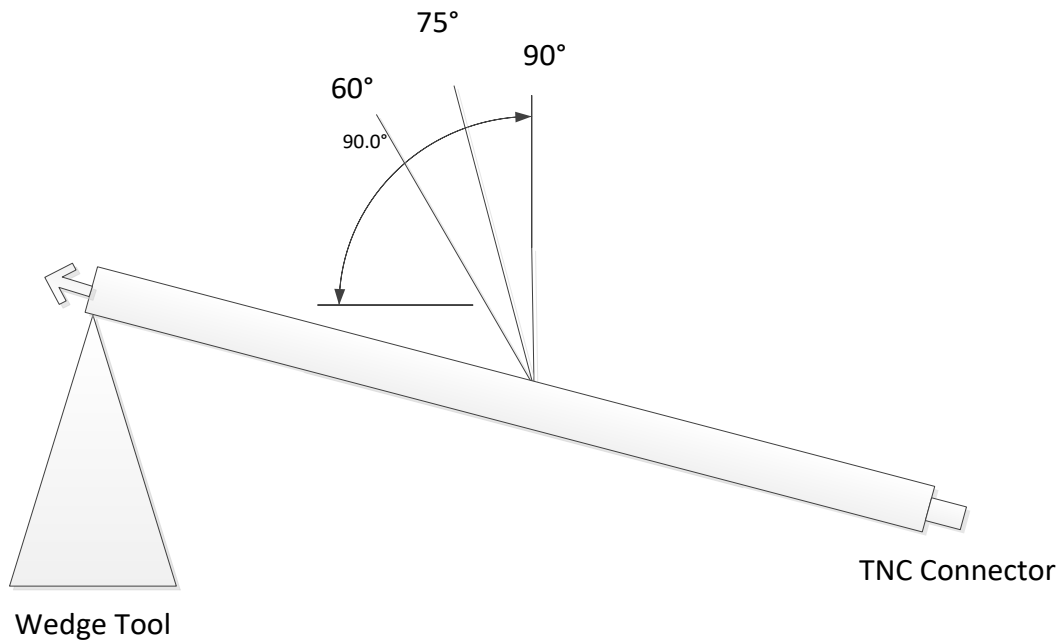

Figure 4-8: 60°- 90° Elevation Angle

Post Antenna Pointing

Once you have the antenna pointed and you have successfully registered with the network, if necessary, the modem unit can be buried and the antenna covered with a thin layer of sand, soil, vegetation material, etc.

NOTICE

It is always good practice to check the connection one more time after you put anything over the antenna. Depending upon what material is used to cover the antenna, the antenna signal strength can be degraded, along with the performance of the terminal.

HUGHES

Home

Connections

Settings

M2M

Security

SMS

LPB

STATUS

Connection

Connected

Beam: NARROW 84

Signal Strength: 66.9

40

40
100

GPS

3D GPS Fix

Location: 32.89572° N
117.20222° W

Last Fix: 07-Aug-2015
18:32 UTC

Pointing Info

I-4 Americas

147.3° 46.5°

Home

Terminal Information

Model	BGAN USER TERMINAL, Hughes LPB
IMEI	353938-03-002217-6
Software Version	5.9.4.3

SIM Information

IMSI	901112112489879
APN	bgan.inmarsat.com
Subscriber Phone Number	Not configured by Service Provider.

Troubleshooting

Terminal Logs

Log Type	Current Log	Archived Log	Reset Log
To download the logs to disk, Click or right-click the links below and select 'Save Target As'.			
System Log	Download Current		
Event Log	Download Current	Download Archive	<input type="button" value="Reset Event Log"/>
Packet Log	Download Current	Download Archive	<input type="button" value="Reset Packet Log"/>

Reset Terminal to Factory Defaults

Click this button to restore all terminal settings to their original default values.

Reboot Terminal

Click this button to reboot the terminal software.

Figure 4-9 – Signal Strength on Home Page

LED Flow Chart

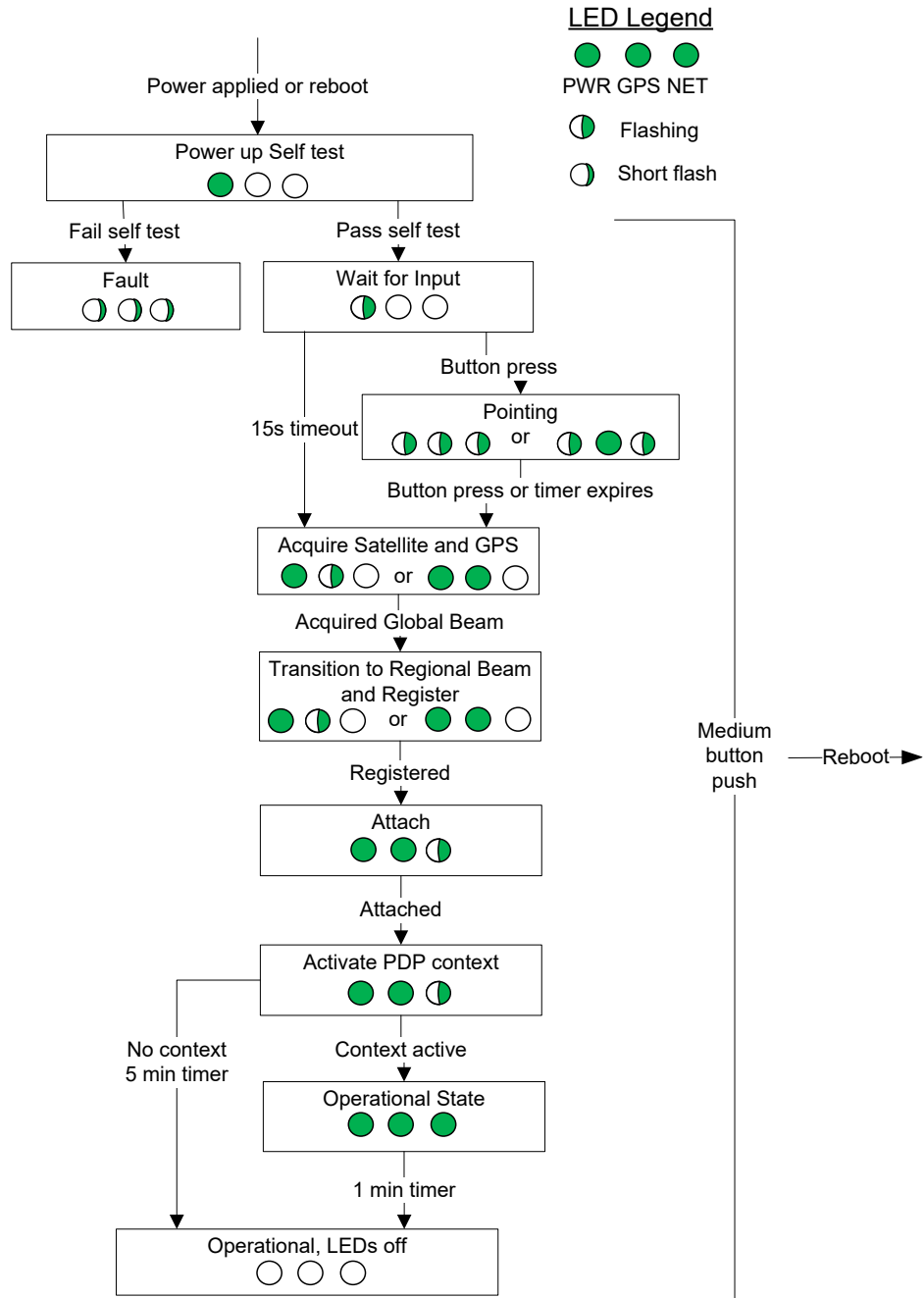

Figure 4-10 – LED Flow Chart

NOTICE

Important Notes:

- To aid in pointing the antenna, there is a 3.5mm stereo audio jack port on the LPB. The user can insert a stereo headset to hear audio tones or use a voltmeter to measure the voltage which indicates the quality of the signal detected during install mode.
- The unit must have DC power applied for pointing.
- The GPS antenna is an integral part of the main antenna and a GPS fix can be obtained as part of the pointing process.



- Once you are out of pointing mode, you need to stay away from the front and sides of the antenna at least 1m for safety purposes.

Exit Pointing Mode

1. Short press the function button (<2 seconds) to exit pointing mode. The terminal will initiate registration with the network.
2. Verify the unit registers, attaches, and establishes a PDP context by checking the status on the Web UI or when all three of the LEDs are solid green (Figure 4-10 – LED Flow Chart).
3. Optionally, verify the unit will correctly recover from a power cycle by removing and reapplying power. Verify it registers, attaches, and establishes a PDP context by again checking the status on the Web UI or when all three of the LEDs are solid green (Figure 4-10 – LED Flow Chart).
4. Verify end to end connectivity of the system, by sending a small amount of data from the device connected to the LPB and verifying that the data was received by the other end (e.g., data center).

NOTICE

5. Ensure the door is closed and tightly sealed to ensure the IP-67 integrity of the unit once again.

Chapter 5 Lightning Protection and Safety

Lightning and Grounding Precautions / La foudre et la terre Précautions



A lightning strike on the unit, mounting hardware or cable may cause death or serious injury and is likely to damage the unit.

La foudre sur de l'unité, le matériel de montage ou les câbles peut causer des blessures graves ou mortelles et est susceptible d'endommager à la de l'unité.

It is therefore essential that the installer does not use an installation location, which is likely to experience a lightning strike, and make suitable grounding and lightning protection arrangements to minimize any possibility of injury or damage. Professional local advice should be sought with respect to these matters. Hughes accepts no liability for any injury or damage caused by lightning strikes.

Il est donc essentiel que l'installateur évite tout emplacement d'installation susceptible d'être frappé par la foudre, et de mettre en place un dispositif de mise à la terre et de protection contre la foudre adapté afin de minimiser tout risque de blessure ou de dommage. Un conseil professionnel local devrait être consulté à cet égard. Hughes n'accepte aucune responsabilité pour tout préjudice ou dommage causé par la foudre.

Hughes LPB chassis shall be connected to earth ground. Connect the earth grounding wire with lug in between the ground screw and chassis. Tighten the ground screw after the wire lug is installed. The wire lug material shall be either tin-plated copper or tin-plated steel.

Le châssis de Hughes LPB doit être connecté à la terre. Connectez le câble de mise à la terre avec une cosse entre la vis de terre et le châssis. Serrez la vis de terre après que le câble avec cosse ait été installé. Le câble avec cosse doit être soit en cuivre zingué ou en acier étamé.

Hughes also recommends that a protective earth cable be connected to the mount. Please consult professional local advice for protective earth grounding requirements.

Hughes recommande également qu'un câble de terre être connecté à la monture. Veuillez consulter un conseil professionnel local pour les spécificités concernant la mise à la terre de protection.

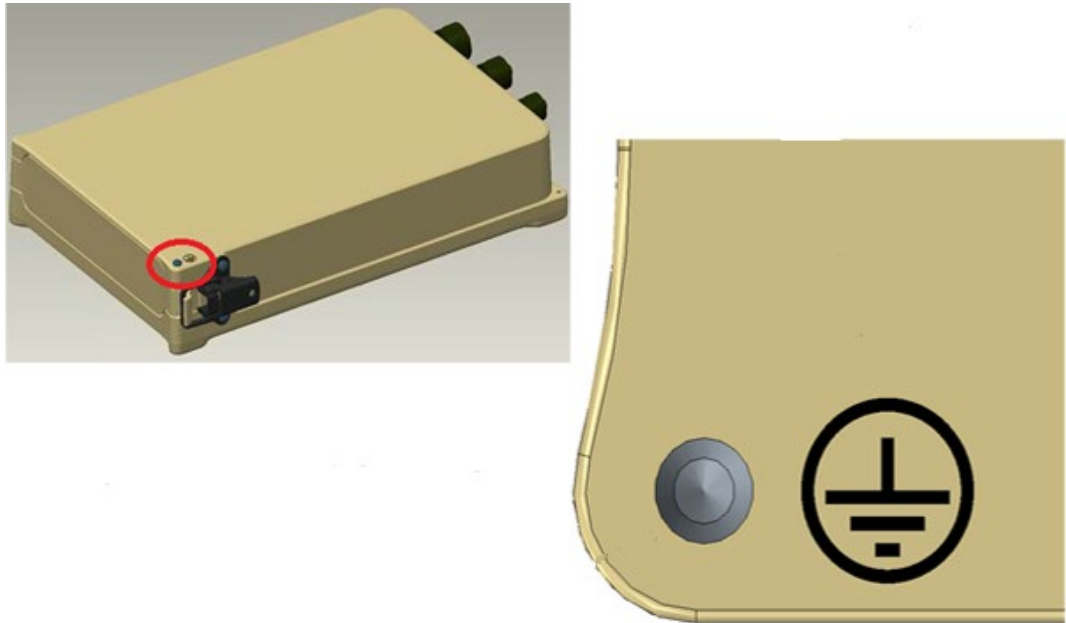

Figure 5-1 – LPB Protective Earth Grounding

Disclaimer / Avertissement

Whilst prepared in good faith, Hughes makes no warranty or representation as to the accuracy, completeness or fitness for purpose of this document or its contents and all warranties, whether express or implied are excluded. Hughes, to the maximum extent permitted by law, excludes any liability arising from the use of this document or its contents. Users' attention is brought to the fact that the local applicable laws and regulations as to the use of the unit may apply and it is the user's responsibility to identify and comply with these.

Tout en étant rédigé de bonne foi, Hughes n'offre aucune garantie ou représentation quant à l'exactitude, l'exhaustivité ou l'adéquation quant à l'objectif de ce document ou son contenu, et toutes garanties, exprimées ou tacites sont exclues. Hughes, dans la mesure maximale permise par la loi, exclut toute responsabilité découlant de l'utilisation de ce document ou son contenu. L'attention des utilisateurs est attirée sur le fait que les lois et réglementations locales applicables à l'utilisation de l'unité peuvent s'appliquer et il est de la responsabilité de l'utilisateur de les identifier et de s'y conformer.

Chapter 6 AT Unsolicited Response Codes

The following codes and text may appear as unsolicited response codes on the AT interface to the UT or in an SMS response to an ATCO Remote SMS command. Each code appears in the following format:

<crLf><at_command>: <#>, <text><crLf>

Where:

<crLf> is the carriage-return/line-feed character sequence

<at_command> identifies the command which generated the response

<#> is the numeric response code

<text> is descriptive text about the response

Examples:

_IGETFW: 20, FTP hookup fail

_IUPDFW: 0, Complete

The message format is intended to be readable/usable by both automated processes and humans.

Table 6 below shows the current set of response codes, grouped by function.

Code	Text	Explanation
General		
0	Complete	Operation completed successfully
1	Unexpected software error	Software error
2	Local file open error	_IGETFW: could not open local file for download _IUPDFW: could not open control file for update parameters _IUPDCFG: could not compute checksum for new config file.
3	Directory not found	Could not find specified directory on UT file system.
4	File not found	Could not find named file (on local file system).
5	Error renaming file	_IUPDFW: Could not restore 'image.txt' after failed upgrade. _IUPDCFG: Could not rename new file to 'config.txt'.
6	Parameter error	Error found in a parameter, e.g. invalid value, string too long, etc.
Context Management		
10	No entry in context table	No free entry in context ID table (all 11 contexts in use)
11	Context parameter error	Internal software error
12	Local IP addr error	Internal software error
13	Context activation error	Context activation failed. Could be problem with PS attach, SIM subscription, APN, network or connectivity.
14	Context deactivation error	Context deactivation failed
FTP Management		
20	FTP hookup fail	Connection to FTP server failed. Problem could be server unreachable or specified IP address or server name invalid, or connectivity failure.
21	FTP login fail	FTP username or password incorrect

22	FTP 'type' fail	Could not establish "binary" mode.
23	FTP 'cwd' fail	Could not change to working directory on FTP server.
24	FTP data connection fail	Could not establish an FTP data connection with the server.
25	FTP 'nlst' fail	Could not get list of files in current FTP server directory. Directory may be empty.
26	FTP xfer command fail	Could not initiate data transfer on an established connection. May be caused if filename not found.
27	FTP found no filename	Could not find a filename in the current server directory.
28	FTP local file read/write fail	Error while writing downloaded file to UT flash or reading upload file data.
29	FTP socket fail	Error while reading or writing FTP data socket.
30	FTP completion error	Error while closing the current FTP connection.
31	FTP xfer timed out	FTP client timed out waiting for socket ready (read or write), e.g. due to loss of connectivity during transfer.
_IGETFW		
40	File in use, cannot download	The file to be downloaded is the same (by name) as the image currently in use.
41	Starting immediate update...	Normal success. File downloaded successfully, now starting immediate update.
42	Complete	The file listed in the response was successfully downloaded to the UT.
43	Downgrade disallowed	Downgrade to lower release blocked to protect hardware.
_IUPDFW		
50	New firmware file not found	Could not find filename specified in upgraded control file.
51	New firmware file corrupt	Firmware file failed checksum test.
52	New firmware file failure	The new firmware failed to run or failed to acquire the network and the unit fell back to the old release.
53	Upgrade admin file error	Problem with local file manipulation during upgrade process.
54	Upgrade status file error	Problem with local file manipulation during upgrade process
_IGETFILE		
60	Can't overwrite protected file	File specified in AT command was 'config.txt', 'config.chk', 'config_bk.txt', 'config_bk.chk'
_IUPDCFG		
70	Can't use reserved file	Attempt to use one of protected config files as the new config.txt file.
_IREMWEB		
80	Invalid IP address string	An IP address parameter string could not be interpreted as a legitimate IP address.
81	Global IP: <ip_addr>	REMWEB connection set up successfully. Indicates global IP address assigned to the UT's own PDP context, to which an HTTP connection may be made.

Table 6 - AT Unsolicited Response Codes

Chapter 7 Troubleshooting

Problem	Possible Cause	Possible Solution
Ethernet connectivity problems	The LPB Ethernet chip is 10BaseT and some routers and other devices may have problems if set to 100BaseT or auto-negotiate	Configure the device for 10BaseT
Problems with remote control SMS when sending from cell phone	The Inmarsat network does not interconnect for SMS with all cellular carriers. Some only work in one direction.	Test SMS from cell phones to BGAN before deploying to verify interconnectivity. Alternatively, use another BGAN terminal to send and receive SMS or use the Remote Terminal Manager feature from Inmarsat.
Problems with remote control SMS	Most remote SMS problems are caused by configuration or syntax problems.	Verify the UT has remote SMS enabled. Verify you are using the correct password. If the white list is configured, verify you are initiating messages from a device with an allowed number. Check the syntax of the SMS against the SMS Remote Control Feature User Guide. Spaces are used as delimiters between parameters and must be used correctly. Some parameters require double quotes, e.g. APN such as "bgan.inmarsat.com"

PDP Context Activation Errors

CME error number	CME Error Text on Web UI	Possible reason
14	invalid index	Problem in PDP context request
21	no network service	Could be poor signal or signal blockage, or network problem.
55	Implicitly detached (#10)	Check attach and registration status.
62	Network failure (#17)	Could be problem accessing the network; or could be invalid streaming rate or too many streams requested.
65	Congestion (#22)	Insufficient resources in the spot beam. Retry later.
67	Service option not supported (#32)	Invalid context parameters or subscription problem.
68	Requested service option not subscribed (#33)	Requested invalid APN or SIM subscription problem.
69	Service option temporarily out of order (#34)	Retry activating the context, then try rebooting the unit.
70	No PDP context activated (#40)	Retry activating the context, then try rebooting the unit.
72	PDP authentication failure	Could be invalid APN username or password
74	Semantically incorrect message (#95)	Could be problem in TFT definition or PDP context request.
75	Invalid mandatory information (#96)	Problem in PDP context request
76	Message type non-existent or not implemented (#97)	Problem in PDP context request
77	Message type not compatible with the protocol state (#98)	Problem in PDP context request
78	Information element non-existent or not implemented (#99)	Problem in PDP context request
79	Conditional IE error (#100)	Problem in PDP context request
80	Message not compatible with the protocol state (#101)	Problem in PDP context request
81	Protocol error, unspecified (#111)	Problem in PDP context request
92	Network access forbidden	Retry activating the context, then try rebooting the unit. Check the SIM card and SIM subscription.

Table 7 - PDP Context Activation Errors

Chapter 8

Regulatory Notices

FCC Compliance / Conformité FCC

This device conforms to the FCC rules. Any changes or modifications to Hughes Network Systems' equipment, not expressly approved by Hughes Network Systems, could void the user's authority to operate the equipment.

Cet appareil est conforme aux règles FCC. Toute modification apportée à l'équipement de Hughes Network Systems et non approuvée expressément par Hughes Network Systems, peut annuler l'autorisation de l'utilisateur à opérer cet équipement.

To comply with FCC RF exposure requirements, this device must be operated with a minimum separation distance of one meter from the front of the satellite terminal's antenna to a person's body. Other operating configurations should be avoided.

Afin d'être conforme aux exigences FCC concernant l'exposition RF, cet appareil doit être utilisé tout en maintenant une distance de séparation minimale d'un mètre entre la personne et le devant de l'antenne du terminal satellite. Toute autre configuration d'utilisation doit être évitée.

This device complies with Part 15 of the FCC Rules. Operation is subject to the following two conditions; (1) this device may not cause harmful interference, and (2) this device must accept any interference received, including interference that may cause undesired operation.

Cet appareil est conforme à la Section 15 du règlement FCC. Son fonctionnement est sujet aux deux conditions suivantes ; (1) ce matériel ne peut pas provoquer d'interférences nuisibles, et (2) ce matériel doit pouvoir tolérer n'importe quelle interférence reçue, y compris les interférences qui peuvent provoquer un fonctionnement indésirable.

IC Compliance / Conformité IC

This device conforms to Industry Canada's rules. Any changes to Hughes Network Systems' equipment, not expressly approved by Hughes Network Systems, could void the user's authority to operate the equipment.

Cet appareil est conforme aux règlements de l'Industrie Canada. Tout changement à l'équipement de Hughes Network Systems, sans le consentement exprès de Hughes Network Systems, peut résulter à l'annulation de l'autorité confiée à l'utilisateur d'opérer cet équipement.

To comply with Industry Canada's RF exposure requirements, this device must be operated with a minimum separation distance of one meter from the satellite terminal's antenna to a person's body. Other operating configurations should be avoided.

Pour être conforme aux règlements d'Industrie Canada sur l'exposition aux rayonnements RF, cet appareil se doit opérer à une distance d'au moins un mètre entre l'antenne du terminal de transmission satellite et le corps d'une personne. Toute autre configuration d'opération devrait être évitée.

EU WEEE (Waste Electrical and Electronic Equipment) Directives

The European Union (EU) Directive 2012/19/EU on waste electrical and electronic equipment mandates recycling of electrical and electronic equipment throughout the EU.

Unless otherwise noted, all products, assemblies, and sub-assemblies manufactured by Hughes and its sub-contractors are compliant with this directive and any subsequent revisions or amendments. This product carries the WEEE label below to demonstrate compliance.

For additional information, contact Hughes Network Systems at: www.hughes.com.



MIL-STD-810G (15 April-14) Low Pressure Procedure I

The Low Profile BGAN terminal was tested to MIL-STD-810G for altitude on 13-October-2014 per the product requirements specification. The altitude requirement was for 15,000 feet or 4,572 meters. An over-air test was successfully completed on the unit after being subjected to the altitude requirement.